I-O LanRPC+ Print Server

User's Guide

Copyright and Trademark Notices

Copyright 2005 I-O Corporation.

ALL RIGHTS RESERVED.

Information in this document is subject to change without notice and does not represent a commitment on the part of the manufacturer. No part of this guide may be reproduced or transmitted in any form or means, electronic or mechanical, including photocopying and recording, for any purpose, without the express written permission of the manufacturer.

Every effort has been made to make this guide as complete and accurate as possible, but no warranty of fitness is implied. The authors and the publisher shall have neither responsibility nor liability to any person or entity with respect to loss or damages arising from the use of information contained in this guide. This disclaimer does not apply in countries where such provisions are inconsistent with local law.

I-O[®] is a registered trademark of I-O Corporation. All trademarks are acknowledged.

Document Number: LanRPC Plus-QMAN01-569

June 2014

I-O Corporation
14852 South Heritage Crest Way
Unit 1-A
Bluffdale, Utah 84065
(801) 973-6767
(800) 871-9998

www.iocorp.com

Preface

Thank you for purchasing the I-O LanRPC+ Print Server. This guide contains information to setup and use the Print Server.

The guide consists of the following chapters:

- **Introduction:** Provides an overview of the product.
- **Installation:** Provides detailed information on the installation of the hardware, the installation of I-O Configuration Utility for remote management of I-O LAN based products, configuration of the LanRPC+, and configuration of the AS/400, iSeries or i5 host.
- **LanRPC+ Operation:** Provides detailed instructions on the use of a printer session.
- **Troubleshooting:** Provides solutions to problems that may be encountered while using the product.
- **Manufacturer's Warranty & Repair Policy:** States the warranty and how to obtain service and support.

The following symbols are used in the guide.



Caution: This symbol highlights procedures that, if not correctly performed or adhered to, could damage or corrupt the product or adversely affect the security and functionality of the product. Do not proceed beyond such points until the required conditions are fully understood and achieved.



Note: This symbol denotes useful additional information that is relevant to the procedure or feature being described.



Tip: This symbol denotes a hint, shortcut or alternate method to aid or supplement the procedure being described.

Consistent with our policy of continuous development, the product you received may have features different from those described in this guide. Please visit our web-site www.iocorp.com for current information.

Table of Contents

| | |
|---|-----------|
| INTRODUCTION | 6 |
| OVERVIEW..... | 6 |
| STANDARD FEATURES | 6 |
| UNPACKING | 6 |
| ABOUT THE LANRPC+ PRINT SERVER | 7 |
| <i>LED Indicators</i> | 7 |
| <i>Physical Connectors</i> | 8 |
| INSTALLATION..... | 9 |
| HARDWARE INSTALLATION | 9 |
| INSTALL THE I-O CONFIGURATION UTILITY | 9 |
| <i>Linux Configuration</i> | 9 |
| CONFIGURE THE AS/400, ISERIES OR ESERVER I5 HOST | 10 |
| SELECTING THE PROTOCOL TO COMMUNICATE WITH THE LANRPC+ | 10 |
| CONFIGURE THE HOST TO USE TN5250E..... | 11 |
| CONFIGURE THE HOST TO USE ANYNET | 12 |
| <i>AnyNet Configuration Worksheet</i> | 12 |
| <i>Setting the Host Values</i> | 14 |
| <i>Enable Auto Configuration</i> | 14 |
| CREATING AN ANYNET CONTROLLER..... | 14 |
| <i>Creating a TCP/IP Host Table Entry</i> | 15 |
| <i>Adding a Remote Configuration List</i> | 16 |
| CONFIGURING THE HOST FOR IPDS PRINTING..... | 17 |
| <i>Requirements</i> | 17 |
| <i>Creating a Line Description on the AS/400</i> | 17 |
| <i>Configuring a TCP/IP Host Table Entry</i> | 18 |
| <i>Configuring V3R1 or V3R6</i> | 18 |
| <i>Configuring V3R2</i> | 19 |
| <i>Configuring V3R7 or V4R1</i> | 20 |
| <i>Configuring V4R2 and Above</i> | 22 |
| <i>Verifying the IPDS Configuration on the AS/400</i> | 24 |
| CONFIGURE THE LANRPC+ PRINT SERVER | 25 |
| SETTING THE GENERAL INFORMATION AND IP ADDRESS | 25 |
| SELECT THE HOST COMMUNICATION PROTOCOL | 27 |
| CONFIGURE THE LANRPC+ TO USE TN5250E..... | 28 |
| CONFIGURE THE LANRPC+ TO USE ANYNET..... | 30 |
| CONFIGURE THE LANRPC+ TO USE SNA - (SNA IS NOT SUPPORTED) | 32 |
| CONFIGURE THE LANRPC+ FOR IPDS PRINTING VIA PPR/PPD | 33 |
| LANRPC+ OPERATION | 34 |
| SHARING A PRINTER WITH MULTIPLE HOSTS | 34 |
| TN5250E OPERATION..... | 34 |
| <i>Starting a Printer Session</i> | 34 |
| <i>Re-Connect a Session</i> | 35 |
| <i>Disconnect a Session</i> | 35 |
| <i>How Telnet Names a Device</i> | 35 |
| ANYNET OPERATION..... | 36 |
| <i>Starting a Printer Session</i> | 36 |
| <i>Re-Connect a Session</i> | 36 |
| <i>Disconnect a Session</i> | 36 |
| <i>How AnyNet Names Devices</i> | 36 |
| SNA OPERATION..... | 37 |
| IPDS OPERATION VIA PPR/PPD | 37 |

| | |
|---|-----------|
| TROUBLESHOOTING | 38 |
| GENERAL ERROR CONDITIONS | 38 |
| GENERAL LANRPC+ STATUS MESSAGES | 41 |
| TN5250E HOST COMMUNICATION STATUS MESSAGES | 42 |
| TN5250E PRINTER CONNECTION STATUS MESSAGE | 43 |
| ANYNET HOST COMMUNICATION STATUS MESSAGES | 46 |
| IPDS ERROR CONDITIONS | 48 |
| LED INDICATORS | 48 |
| FIRMWARE UPGRADE PROCESS | 49 |
| I-O CONFIGURATION UTILITY UPGRADE PROCESS | 50 |
| UNINSTALLING THE I-O CONFIGURATION UTILITY | 50 |
| RESTORING FACTORY DEFAULTS | 50 |
| <i>Restoring Factory Defaults Using the I-O Configuration Utility</i> | 50 |
| <i>Configuring a new IP address on the LanRPC+</i> | 51 |
| HOST COMMUNICATION TRACE..... | 51 |
| <i>Start a Trace</i> | 51 |
| <i>End a Trace</i> | 51 |
| <i>Print a Trace</i> | 51 |
| MANUFACTURER’S WARRANTY & REPAIR POLICY | 52 |

Introduction

This chapter provides a brief overview of the I-O LanRPC+ Print Server.

Overview

The I-O LanRPC+ Print Server is built on a Linux platform and designed to connect one IBM Twin-ax printer to IBM AS/400, iSeries or i5 midrange computer systems via Ethernet using industry standard TCP/IP protocols. Configuration of the LanRPC+ is accomplished through I-O's simple and easy to use remote administration software, the I-O Configuration Utility.

Standard Features

I-O LanRPC+ Print Server contains the following features:

- Attaches a single twin-ax printer
- Connects up to a maximum of 4 hosts
- Supports TCP/IP (TN5250e, AnyNet) for remote and local connections
- When using TN5250e, the host configures SCS printers as 3812-1, the LanRPC+ converts 3812-1 commands to 4214, 5224, 5225, or 5256 depending upon the printer attached.
- When using TN5250e, an SCS printer session allows you to select HPT (host print transform) for applications which require a work station customizing object.
- When using AnyNet, the host recognizes all SCS and IPDS printer's native model types
- Support of PPR/PPD configuration for an IPDS printer with a host license for PSF/400.
- 10/100BaseT RJ45 auto-sensing connector
- Ethernet (IEEE 802.2, 802.3)
- DHCP client

Unpacking

When you receive the LanRPC+, check the packaging for water or physical damage, and notify the carrier immediately if any damage is evident. Keep the original packaging in case the interface needs to be moved or shipped. The following items are included in the package:

- An I-O LanRPC+ Print Server
- A CD-ROM containing:
 - I-O LanRPC+ Print Server User's Guide
 - I-O Configuration Utility
- Getting Started Guide
- Power Supply

About the LanRPC+ Print Server



LED Indicators & Power Button on the Unit

| | |
|----------|---|
| Link | This LED will be on indicating the Print Server has a good link with the Ethernet LAN. |
| Activity | This LED will flash on and off as Ethernet packets are detected on the LAN. |
| Power | This LED (blue circle around power button) indicates when the Print Server is powered on. |
| Ready | <p>In the Ready state, this Host Communication Status LED can have one of four values:</p> <ul style="list-style-type: none">• Off with a slow flash – No host connection. Make sure the host configuration is correct and the LRPC+ sees a printer. Line 1 on solid.• Off with a slow flash and Line light on solid – The LanRPC+ is communicating with the printer, but the host is not responding.• Off with a fast flashing Line light – No network connectivity. Boot failed.• On solid with a solid Line light – The LanRPC+ is communicating with the host and printer. |
| Line 1 | <p>When power is first plugged into the LanRPC+ the Line LED will be off with a 4 second heart beat. In the Ready state, this Twin-ax Cable Status LED indicates whether a twin-ax device is currently responding to polls.</p> <ul style="list-style-type: none">• On solid – Indicates that a printer is responding to polls.• Off with a heartbeat – Indicates no device is currently responding on the cable or there is a cable issue. |

Physical Connectors

| | |
|-----------------------|---|
| 5250 Twin-ax | The twin-ax turret, Line 1 is used for connecting your printer, whether through twin-ax cable or a star panel. |
| External Power Supply | The power transformer is a 110 or 220 VAC to 12VDC 3.3A  switching power supply. |
| RJ45 | This RJ45 connector is where the Ethernet cable is attached. The LanRPC+ will automatically link at the speed of the network. |
| DB15 | The DB15 connector is used to attach a display for configuration or diagnostic purposes beyond those offered in the Configuration Utility. |
| USB | The USB ports are used for connecting a keyboard and USB Stick for configuration and firmware update purposes. |

Installation

No special training is needed to install the I-O LanRPC+ Print Server. There are four phases involved in setting up the Print Server:

1. Install the unit – see Hardware Installation in this chapter.
2. Install the I-O Configuration Utility – see Install the I-O Configuration Utility in this chapter.
3. Configure the AS/400, iSeries or eServer i5 host – see the Configure the AS/400, iSeries or eServer i5 Host chapter.
4. Configure the LanRPC+ – see Configure the LanRPC+ chapter.

Hardware Installation

1. Inspect the package for damage.
2. Connect the Twin-ax cable to the turret.
3. Connect the Ethernet cable.
4. Power on the printer.
5. Connect the power cord to the unit and a wall outlet.

Install the I-O Configuration Utility. Need V4.73 or higher.

The I-O Configuration Utility is used to configure the LanRPC+. It is also used to help diagnose connection problems.

1. Insert the I-O Configuration Utility CD in the CD-ROM drive of a Windows XP or newer PC.
2. Click Start | Run, and enter “d:\configuration utility\setup.exe”, click OK.
3. Follow the on screen prompts.
4. Navigate to the I-O Configuration menu and start the I-O Configuration Utility.



NOTE: THE I-O CONFIGURATION UTILITY IS A REMOTE ADMINISTRATIVE UTILITY USED TO SETUP I-O LAN BASED PRODUCTS INCLUDING CONTROLLERS, PRINT SERVERS, AND THE LANRPC+. IT'S RECOMMENDED THAT THE MOST RECENT VERSION OF THE I-O CONFIGURATION UTILITY ALWAYS BE USED. THE MOST RECENT VERSION IS AVAILABLE ON I-O'S FTP SITE, <FTP://FTP.IOCORP.COM/UTILITIES/CONFIGURATION UTILITY/>



THE LANRPC+ REQUIRES A DHCP SERVER TO ASSIGN AN IP ADDRESS IN ORDER FOR THE CONFIGURATION UTILITY TO SEE THE PRINT SERVER. IF YOU DON'T HAVE A DHCP SERVER OR IF AN IP ADDRESS FAILS TO GET ASSIGNED, YOU WILL NEED TO CONNECT A MONITOR AND KEYBOARD TO THE VGA AND USB PORTS ON THE BACK OF THE PRINT SERVER. THE LANRPC+ USES A LINUX OS, WHICH WILL TAKE A FEW MINUTES TO BOOT. AFTER BOOTING UP, PRESS ENTER TO GET A REQUEST FOR LOGIN AND PASSWORD. THE USER IS 'ROOT' AND THE PASSWORD IS 'IO-0001'.

AFTER LOGGING ON, TYPE THE COMMAND: `./SETIPADR` AND FOLLOW THE PROMPTS TO ENTER THE IP ADDRESS, SUBNET MASK AND GATEWAY. ENTER THE COMMAND 'EXIT' AND REBOOT THE LANRPC+.

AFTER REBOOTING, REFRESH THE CONFIGURATION UTILITY AND YOU SHOULD SEE THE LANRPC+.

Configure the AS/400, iSeries or eServer i5 Host

Prior to configuring the I-O LanRPC+ Print Server, it will be necessary to configure the AS/400, iSeries or eServer i5 host. Configuring the host involves determining which of two protocols to use for communicating with the Print Server, and then setting up the appropriate configuration settings on the host.

Selecting the Protocol to Communicate with the LanRPC+

Two protocols are available to connect to the AS/400, iSeries or eServer i5 host. Both protocols are auto configuring on the host. Choose the protocol based upon the type of printer that is being attached to the host.



NOTE: THE LANRPC+ WILL SUPPORT UP TO FOUR HOSTS. ON THE FIRST HOST, EITHER OF THE TWO PROTOCOLS, TN5250E OR ANYNET MAY BE SELECTED. ON THE SECOND, THIRD AND FOURTH HOSTS, ONLY TN5250E MAY BE USED.

- **TN5250e** is a routable protocol. This means that it can be used at remote locations (or where there is a router between the Print Server and the host). It is the easiest protocol to setup for SCS or IPDS printers. When configuring an IPDS Printer using the TN5250 protocol, you must have PSF/400 installed and manually configure a PSF Object and the IPDS Printer on the iSeries Host. Use the IP Address of the LanRPC+ as the Remote Location and the proper Port Number shown on Page [23](#) based on the Twin-ax Address of the IPDS Printer.

A Non-IPDS Printer is auto configured on the host as a 3812-1 SCS page printer. The LanRPC+ will customize the data stream to the attached twin-ax printer's capability removing SCS commands the printer cannot support. This allows a printer like a 4214, 5224, etc. to be attached. However, TN5250e is limited in that it does not support posting the dot-matrix form alignment message (see note) as well as the IBM dot-matrix functions of backspace, bold, underscore or overstrike.



TIP: TN5250E IS RECOMMENDED WHEN THE PRINTER IS SCS OR IPDS WITH A HOST LICENSE FOR PSF/400, IS A 3812-1 LASER PRINTER OR DOT-MATRIX PRINTER NOT AFFECTED BY THE BACKSPACING LIMITATIONS.



NOTE: FORMS ALIGNMENT MESSAGES ON DOT MATRIX PRINTERS CAN BE ENABLED BY CHANGING THE FORM FEED PARAMETER IN THE PRINTER CONFIGURATION TO: *CONT.

- **AnyNet** is actually SNA encapsulated in TCP/IP and is a routable protocol. It is more difficult than TN5250e to initially configure, but has the advantage of reporting to the host the twin-ax device's native model so the actual device will be auto configured by the host. AnyNet does not have the limitations of TN5250e in that it fully supports all SCS and IPDS printers.



TIP: ANYNET IS THE RECOMMENDED PROTOCOL TO USE WHEN CONNECTING AN IPDS PRINTER WHEN THE HOST DOES NOT HAVE A LICENSE FOR PSF/400 OR WHERE THERE IS AN IBM SCS DOT-MATRIX PRINTER WHICH IS PRINTING APPLICATIONS THAT REQUIRE FEATURES NOT SUPPORTED BY TN5250E.

- **IPDS via PPR/PPD.** This TCP/IP protocol is used by IBM hosts to communicate with LAN attached IPDS printers. This is the preferred protocol over using AnyNet for IPDS printing when the host has a license for PSF/400.

PPR/PPD does require the configuration of host 1 with the TN5250 protocol in order for the LanRPC+ to communicate with the printer. This is in addition to assigning the LanRPC+ an IP

Address, sub-net mask, and default router (if applicable). All other setup is done on the IBM host side.



NOTE: IBM REQUIRES A LICENSE FOR PSF/400 IN ORDER TO PRINT IPDS OVER IP. IF YOU DO NOT HAVE A LICENSE FOR PSF/400, USE THE ANYNET PROTOCOL.

Configure the Host to use TN5250e

To configure the AS/400, iSeries or eServer i5 host to support TN5250e, the host must meet the following requirements:

- Be running OS/400 V3R2 or newer, with the most recent applicable PTFs applied.
- Have the most recent version of the Telnet server installed on the host.
- Have the host's auto configuration function turned on. This is done using the host command:

CHGSYSVAL QAUTOCFG

Find the "Auto configure device" entry, and set the value to "1".

- Make certain the host can create virtual devices and there are a sufficient number of devices available to be created. This is done using the host command:

CHGSYSVAL SYSVAL(QAUTOVRT)

In the New Value field, enter the maximum number of user-created virtual devices that can be created.

- If the OS/400 version is earlier than V4R2, the Telnet server will need to be started using the host command:

STRTCPSVR SERVER(*TELNET)

V4R2 and newer versions will automatically start the Telnet server.

- Identify the host's TCP/IP address. This will be used in configuring the LanRPC+. This is done using the host command:

CFGTCP

Take option "1. Work with TCP/IP interfaces", look for the Network Card under Line Description and *record the host's TCP/IP address* as it will be used when configuring the LanRPC+.

After these requirements are met and the host settings are completed, the AS/400, iSeries or eServer i5 host will automatically configure the SCS printer the first time you attempt to make a connection. The IBM host will use the Telnet device name created from the default name entered or the name manually entered when configuring the printer.

SCS printers are auto configured on the host as 3812-1 page printers. The LanRPC+ will customize the data stream sent to the attached twin-ax printer, removing SCS commands the printer cannot support, allowing a printer like 4214, 5224 etc. to be attached. If forms and alignment messaging for a line or dot matrix printer is necessary, you will need to change the Form Feed option in the printer configuration to *CONT. If you are using other printing features not supported by TN5250 – use the AnyNet protocol. Using TN5250 for an IPDS printer, IBM requires a license for PSF/400.

Configure the Host to Use AnyNet

The process of configuring the AS/400, iSeries or eServer i5 host includes:

1. Fill out the AnyNet Configuration Worksheet that will be used when configuring the LanRPC+.
2. Setting the host values so the host will auto configure the LanRPC+ and its attached printer when the LanRPC+ is brought on line.

AnyNet Configuration Worksheet



TIP: PRINT THIS WORKSHEET AND FILL IN THE REQUIRED VALUES. YOU WILL USE THIS INFORMATION WHEN SETTING UP THE LANRPC+.

Host TCP/IP Address

The AS/400, iSeries or eServer i5 host's Local Adapter Address is: _____ . _____ . _____ . _____

1. On the host command line, enter **CFGTCP**, press ENTER.
2. Select Option 10 – Work with TCP/IP Host Table Entries, press ENTER. Scroll down until you find an entry with the host's name (the Local Control Point name). Write the IP address in the blank above.
3. As an alternate to step 2, select Option 1 – Work with TCP/IP Interfaces, press ENTER. The IP address will be shown on the entry with a line type of “*ELAN”. Write the address in the blank above.

Host Control Point Name

The AS/400, iSeries or eServer i5 host's Host Control Point Name is: _____

1. On the host command line, enter **DSPNETA**, press ENTER.
2. Locate the **Local Control Point Name**. Write the name in the blank above.

Host Network ID

The AS/400, iSeries or eServer i5 host's Host Network ID is: _____

1. On the host command line, enter **DSPNETA**, press ENTER.
2. Locate the **Local Network ID** field. Write the name in the blank above.

Interface Control Point Name

The Interface Control Point name the host will use is: _____

This name must be unique and meet the following requirements:

- The name can be no shorter than two characters and no longer than eight characters in length.
- The name must start with an alpha character (A-Z).
- The name must contain only alpha-numeric characters (A-Z, 0-9).
- The first four characters must uniquely identify the LanRPC+, since the Print Server will automatically create a printer on the host using the first four characters of this name followed by five additional host assigned characters. If using a host naming scheme, the first three characters can be the same with the fourth being different.

AnyNet Controller and Remote Control Point Names

The AnyNet Controller Name is: _____

The AnyNet Remote Control Point Name is: _____



NOTE: IF THERE IS NOT AN ANYNET CONTROLLER ALREADY CONFIGURED ON THE HOST, YOU WILL NEED TO CREATE ONE. THEN COME BACK TO THIS WORKSHEET AND FILL IN THE BLANKS USING THE INSTRUCTIONS BELOW. REFER TO THE CREATING AN ANYNET CONTROLLER SECTION FOR INSTRUCTIONS ON CREATING A NEW CONTROLLER.

Generally, it is recommended that one AnyNet Controller on the host be shared with all LanRPC+'s. When configuring the AnyNet Controller and Remote Control Point names on the host, the same name may be used for both. This name is different from the Interface Control Point Name for the LanRPC+.

However, if your host supports more than 254 AnyNet devices, configure one AnyNet Controller for each LanRPC+. In this case, the AnyNet Controller Name, the AnyNet Remote Control Point Name and the Interface Control Point Name for the LanRPC+ must be the same name.

If there is already an AnyNet Controller defined on the host and you plan to use the LanRPC+ under the host's AnyNet Controller, do the following:

1. On the host command line, type **WRKCTLD**, press ENTER.
2. Locate the AnyNet Controller (it will have a Type of "**APPC"), enter the value "5" in front of that Controller. Press ENTER.
3. Locate the Link Type field. If it has a value of "**ANYNW", continue to the next step. Otherwise, press F12, and repeat steps 2 and 3 on each AnyNet Controller until the right Controller is found.
4. Locate the Controller Description field and write the name in the blank for the AnyNet Controller Name above.
5. Locate the Remote Control Point name and write the name in the blank for the AnyNet Remote Control Point Name above.

Setting the Host Values

Before installing the LanRPC+ the host's system values must be set to allow AnyNet Communication and auto configuration of devices.



TIP: USE THE INFORMATION ON THE ANYNET WORKSHEET FOR SETTING THE HOST VALUES IN THIS SECTION.

Enabling AnyNet

AnyNet support must be enabled on the host. Check the current setting by doing the following:

1. On the host's command line, enter **DSPNETA**, press ENTER.
2. Scroll down to the last page of the available parameters. If the Allow AnyNet Support value is set to *No, return to the command prompt (press the CMD3 key).
3. On the host's command line, enter:

CHGNETA ALWANYNET(*YES)

Enabling Auto Configuration

Make certain that the AS/400, iSeries or eServer i5 host is set up for auto-configuration of new devices by doing the following:

1. On the host command line, enter **CHGSYSVAL SYSVAL(QAUTOCFG) VALUE('1')**, press ENTER.
2. On the host command line, enter **CHGSYSVAL SYSVAL(QAUTORMT) VALUE('1')**, press ENTER.
3. On the host command line, enter **CHGSYSVAL SYSVAL(QAUTOVRT) VALUE('512')**, press ENTER. The Number of devices to auto configure should be large enough to account for all virtual (APPC) devices on your network. If you are unsure, you may want to increase this number by using the CHGSYSVAL command.
4. On the host command line, enter **WRKLIND**, press ENTER. Enter a 2 to change or 5 to display in front of the line the LanRPC+ is attached to. Press ENTER several times until Autocreate Controller is displayed in the lower section of the menu options. Verify that the **Autocreate Controller** parameter is set to *Yes.

Creating an AnyNet Controller



NOTE: IF YOU ALREADY HAVE AN ANYNET CONTROLLER DEFINED ON YOUR HOST, SKIP TO THE SECTION, VARYING ON THE ANYNET CONTROLLER.

I-O recommends only one AnyNet APPC Controller on the host. However, this limits the maximum AnyNet devices to 254. If there are more than 254 AnyNet devices on the host I-O recommends creating one AnyNet Controller for each LanRPC+.

To Create a "Global" AnyNet Controller

1. On the host command line, enter **CRTCTLAPPC**, press F4.
2. In the Controller Description field, enter the name of your choice. I-O recommends "ANYNET".
3. In the Link Type field, enter ***ANYNW**.
4. Press ENTER.
5. In the Remote Net ID field, enter ***NETATR**.
6. In the Remote Control Point Name, enter the name of your choice. I-O recommends "AnyNet".
7. Press ENTER.

To create one AnyNet Controller for Each LanRPC+

It is possible to create an individual AnyNet Controller for every LanRPC+ attached to the host. However, this approach can be confusing since any programmable AnyNet APPC device will randomly configure under the different APPC Controllers. Although this does not affect operation, it does make it more difficult to locate and administer the various AnyNet APPC devices.

1. On the host command line, enter **CRTCTLAPPC**, press F4.
2. In the Controller Description field, enter the LanRPC+ Name from the AnyNet Worksheet.
3. In the Link Type field, enter ***ANYNW**.
4. Press ENTER.
5. In the Remote Net ID field, enter ***NETATR**.
6. In the Remote Control Point Name, enter the LanRPC+ Name from the AnyNet Worksheet.
7. Press ENTER.

Varying on the AnyNet Controller

Vary On the AnyNet Controller by typing the following on the host command line:

1. **WRKCFGSTS *CTL** [AnyNet Controller Name]
2. Press ENTER.
3. Type a "1" in front of the APPC Controller, press ENTER

Adding the LanRPC+ to the TCP/IP Host Table



NOTE: THIS PROCESS WILL NEED TO BE COMPLETED AFTER THE LANRPC+'S IP ADDRESS HAS BEEN ASSIGNED.



CAUTION: MAKE SURE THE TCP/IP ADDRESS BEING ASSIGNED TO THE LANRPC+ IS NOT BEING USED BY ANOTHER DEVICE. TO DETERMINE IF ANOTHER DEVICE IS USING THE IP ADDRESS, WITH THE LANRPC+ POWERED OFF, PING THE IP ADDRESS. IF THERE IS A RESPONSE, THEN THE IP ADDRESS IS BEING USED BY ANOTHER DEVICE.

1. On your host's command line, enter **CFGTCP**, press ENTER.
2. Select 10 Work with TCP/IP host table entries.
3. Scroll down and make sure the IP address being assigned to the LanRPC+ is not already in use. Then return to the top of the list.
4. Place a "1" on the blank line on top of the list to add a TCP/IP device, press ENTER.
5. Enter the TCP/IP address of the LanRPC+ in the Internet address field.
6. In the Host names field, enter the following: [Interface Control Point Name from the AnyNet Worksheet].[Host Network ID].SNA.IBM.COM

For example: if the Interface Control Point Name is XIP and the Host Network ID is APPN, the value entered would be "XIP.APPN.SNA.IBM.COM".
7. If desired, enter an additional description for the LanRPC+ in the Text description field.
8. Press ENTER.

Changing the AS/400, iSeries or i5's APPN Remote Configuration List

When using one AnyNet APPC Controller for all AnyNet APPC devices, each LanRPC+ needs to be added to the host's APPN remote configuration list. To accomplish this, follow these steps:

1. On the host command line, type **CHGCFGL *APPNRMT**, press ENTER. (If the configuration list does not exist, type CRTCFGL *APPNRMT)
2. Scroll to the bottom of the displayed list and enter the following required information directly from the AnyNet worksheet:

| | |
|-----------------------|----------------------------------|
| Remote Location: | Interface Control Point Name |
| Remote Network ID: | Host Network ID |
| Local Location: | Host Control Point Name |
| Remote Control Point: | AnyNet Remote Control Point Name |
| Control Point Net ID: | Host Network ID |

3. Press ENTER.

Configuring the Host for IPDS Printing

Several steps are required to configure the IBM host system to enable IPDS printing to a twin-ax IPDS printer. These include ensuring that PSF/400 is installed, that your AS/400 has the required PTF's installed and configured properly to support TCP/IP printing, verifying that line descriptions and host TCP/IP table entries are made, creating the PSF object, and configuring the printer device for use with PSF/400. **See the appropriate configuration instructions for the OS Version of your iSeries listed below on the next several pages.**

Requirements

Make sure the AS/400 host is running a version of OS/400 that supports TCP/IP, has PSF/400 installed, and that the most recent PTF's are installed and configured.

The PTF information presented below may have been superseded with more recent releases. For versions not shown below, check with IBM for the appropriate PTF information. Additional information about PTF's to use can be obtained from IBM's AS/400 service Web site:
<http://as400service.rochester.ibm.com>.

OS/400 V3R1

| | |
|---------|--|
| General | C6198310 Cumulative tape or later SF35164 TCP/IP for PSF/400 (order cover letter only) SF24140 IPDS pass through (order cover letter only) |
| Sockets | SF30018 |
| WRKAFF2 | SF40039 |
| PSF/400 | APAR SA44304 |

OS/400 V3R2

| | |
|---------|--------------|
| PSF/400 | APAR SA44304 |
|---------|--------------|

OS/400 V3R6

| | |
|---------|--|
| General | C5346360 Cumulative tape or later SF45620 TCP/IP for PSF/400 (order cover letter only) SF45624 IPDS pass through |
| Sockets | SF30508 |
| WRKAFF2 | SF31461 |
| PSF/400 | APAR SA44304 |

OS/400 V3R7

| | |
|---------|--------------|
| PSF/400 | APAR SA44304 |
|---------|--------------|

Creating a Line Description on the AS/400

If the LanRPC+ and the AS/400 host are not on the same LAN segment, have the system administrator verify there is a route defined in the TCP/IP route List. If there is not a route defined, use the AS/400 **ADDTCPRTE** COMMAND to create a route definition.

Also, verify if a line description has been created for the line to which the LanRPC+ will be attached. If there is not a line description, have the system administrator use the AS/400 **CRTLINETH** to create an Ethernet line description.

Configuring a TCP/IP Host Table Entry

This step is optional – IBM suggests that a host entry may be created in the TCP/IP table. Have the system administrator use the AS/400 **CFGTCP** command to add the host name and TCP/IP address of the printer's Ethernet connection.

Configuring V3R1 or V3R6

PSF/400 for V3R1 or V3R6

The following instructions are used to create a printer device description:

1. At the AS/400 command line, enter the command **CRTDEVPRT**.
2. Press the F11 key to display the keywords.
3. In the "Device Description" (**DEVVD**) field, enter the name of the printer. The name may be comprised of the letters A-Z and numerals 0-9. It must begin with a letter, and a maximum of 10 characters is allowed.
4. In the "Device Class" (**DEVCLS**) field, enter ***RMT**.
1. In the "Device Type" (**TYPE**) field, enter ***IPDS**.
2. In the "Device Model" (**MODEL**) field, enter **0**.
3. In the "Advanced Function Printing" (**AFP**) field, enter ***YES**.
4. In the "AFP Attachment" (**AFPATTACH**) field, enter ***APPC**.
5. In the "Font" (**FONT**) field, enter an appropriate value such as **11**.
6. In the "Form Feed" (**FORMFEED**) field, enter ***AUTOCUT**.
7. In the "Remote Location" (**RMTLOCNAME**) field, enter **TCPIP**.

AFP for V3R1 or V3R6

The following instructions are used to create a data area that is used by PSF/400:

1. At the AS/400 command line, enter the command **WRKAFP2**.
2. Press the F11 key to display the keywords, then press F10 to display additional values.
3. In the "Printer Device Name (**DEVVD**)" field, enter the name of the printer. This name must be identical to the name entered for the device name in the **DEVVD** field in the **CRTDEVPRT** command.
4. In the "IPDS Pass Through" (**IPDSPASTHR**) field, enter ***NO**.

You may want to set this value to ***YES** if you have applications that generate SCS or IPDS data streams that are printed to an AFP printer if the following uses apply:

1) An application like Business Graphics Utilities, GDDM, or Virtual Print that does not support AFPDS is used; or

2) The SCS or IPDS application does not contain any reference to overlay page segments or host font character sets. Certain limitations and other configuration considerations are discussed in IBM's *Printer Device Programming Version 5 (SC41-5713-05)* publication.

5. In the "TCP/IP Support" (**TCPIP**) field, enter ***YES**.

6. In the “Remote System” (**RMTSYS**) field, enter the TCP/IP address of the LanRPC+. You may also enter the host name if you used the optional CFGTCP command to create a TCP/IP Host Table entry.
7. In the “Port” (**PORT**) field, enter a port number based upon which twin-ax address and which line on the LanRPC+ the IPDS printer is attached. Use the following table to assign the port:

| Twin-ax Address | Line1 Port # |
|------------------------|---------------------|
| 0 | 5001 |
| 1 | 5002 |
| 2 | 5003 |
| 3 | 5004 |
| 4 | 5005 |
| 5 | 5006 |
| 6 | 5007 |

For example, if the IPDS printer attached to Line 1 has a twin-ax address of 5, then the value to enter in the Port field would be 5006.

8. In the “Activation Timer” (**ACTTMR**) field, enter ***NOMAX**. This will cause PSF/400 to wait indefinitely for a response to an activation request.
9. In the “Inactivity Timer” (**INACTTMR**) field for V3R1, or “Release Timer” (**RLSTMR**) field for V3R6, enter ***SEC15**. This parameter should be set to a value less than the timeout value on the printer. This is the time PSF/400 will maintain a session with the I-O Printer while there are no spooled files with a status of RDY.

Configuring V3R2

PSF/400 for V3R2

The following instructions are used to create a printer device description:

1. At the AS/400 command line, enter the command **CRTDEVPRT**.
2. Press the F11 key to display the keywords.
3. In the “Device Description” (**DEV D**) field, enter the name of the printer. The name may be comprised of the letters AZ and numerals 0-9. It must begin with a letter, and a maximum of 10 characters is allowed.
4. In the “Device Class” (**DEVCLS**) field, enter ***RMT**.
5. In the “Device Type” (**TYPE**) field, enter ***IPDS**.
6. In the “Device Model” (**MODEL**) field, enter **0**.
7. In the “Advanced Function Printing” (**AFP**) field, enter ***YES**.
8. In the “AFP Attachment” (**AFPATTACH**) field, enter ***APPC**.
9. In the “Font” (**FONT**) field, enter an appropriate value such as **11**.
10. In the “Form Feed” (**FORMFEED**) field, enter ***AUTOCUT**.
11. In the “Remote Location” (**RMTLOCNAME**) field, enter **TCPIP**.

AFP for V3R2

The following instructions are used to create a data area that is used by PSF/400:

1. At the AS/400 command line, enter the command **CRTPSFCFG**.
2. Press F11 to display the keywords, then press F10 to display additional values.
3. In the “PSF Configuration” (**PSFCFG**) field, enter the name of the object.
4. In the “Library” field, enter **QGPL**.
5. In the “IPDS Pass Through” (**IPDSPASTHR**) field, ***NO**.

You may want to set this value to *YES if you have applications that generate SCS or IPDS data streams that are printed to an AFP printer if the following uses apply:

- 1) An application like Business Graphics Utilities, GDDM, or Virtual Print that does not support AFPDS is used; or
 - 2) The SCS or IPDS application does not contain any reference to overlay page segments or host font character sets. Certain limitations and other configuration considerations are discussed in IBM's *Printer Device Programming Version 5 (SC41-5713-05)* publication.
6. In the “Activation Release Timer” (**ACTRLSTMR**) field, enter ***NORDYF**. This will cause PSF/400 to print all spooled files with a status of RDY before releasing the session (which does not terminate the writer).
 7. In the “Release Timer” (**RLSTMR**) field, enter ***SEC15**. This parameter should be set to a value less than the timeout value on the printer. This is the time PSF/400 will maintain a session with the printer while there are no spooled files with a status of RDY.
 8. In the “Remote Location Name or Address” (**RMTLOCNAME**) field, enter the TCP/IP address of the LanRPC+. You may also enter the host name if you used the optional CFGTCP command to create a TCP/IP Host Table entry.
 9. In the “Port” (**PORT**) field, enter a port number based upon which twin-ax address the IPDS printer is assigned. Use the following table to assign the port:

| Twin-ax Address | Line1 Port # |
|-----------------|--------------|
| 0 | 5001 |
| 1 | 5002 |
| 2 | 5003 |
| 3 | 5004 |
| 4 | 5005 |
| 5 | 5006 |
| 6 | 5007 |

For example, if the IPDS printer were attached has a twin-ax address of 5, then the value to enter in the Port field would be 5006.

10. In the “TCP/IP Activation Timer” (**ACTTMR**) field, enter ***NOMAX**. This will cause PSF/400 to wait indefinitely for a response to an activation request.

Configuring V3R7 or V4R1

AFP for V3R7 or V4R1

1. At the AS/400 command line, enter the command **CRTPSFCFG**.
2. Press Enter or F4 to display the keywords.

3. In the “PSF Configuration” (**PSFCFG**) field, enter the name of the object. Remember this name as it will also be entered in the User-Defined Object (USRDFNOBJ) field in the printer device description that will be created in the next section.
4. In the “IPDS Pass Through” (**IPDSPASTHR**) field, enter ***NO**.
 You may set this value to ***YES** if you have applications that generate SCS or IPDS data streams that are printed to an AFP printer if the following uses apply:
 - 1) An application like Business Graphics Utilities, GDDM, or Virtual Print that does not support AFPDS is used; or
 - 2) The SCS or IPDS application does not contain any reference to overlay page segments or host font character sets. Certain limitations and other configuration considerations are discussed in IBM’s *Printer Device Programming Version 5 (SC41-5713-05)* publication.
5. In the “Activation Release Timer” (**ACTRLSTMR**) field, enter ***NORDYF**. This will cause PSF/400 to print all spooled files with a status of RDY before releasing the session (which does not terminate the writer).
6. In the “Release Timer” (**RLSTMR**) field, enter ***SEC15**. This parameter should be set to a value less than the timeout value on the printer. This is the time PSF/400 will maintain a session with the printer while there are no spooled files with a status of RDY.

PSF/400 for V3R7 or V4R1

The following instructions are used to create a printer device description:

1. At the AS/400 command line, enter the command **CRTDEVPRT**.
2. Press the F4 key to display the keywords.
3. In the “Device Description” (**DEVVD**) field, enter the name of the printer. The name may be comprised of the letters A-Z and numerals 0-9, must begin with a letter, with a maximum of 10 characters allowed.
4. In the “Device Class” (**DEVCLS**) field, enter ***LAN**.
5. In the “Device Type” (**TYPE**) field, enter ***IPDS**.
6. In the “Device Model” (**MODEL**) field, enter **0**.
7. In the “LAN Attachment” (**LANATTACH**) field, enter ***IP**. Then press F10.
8. In the “Advanced Function Printing” field, enter ***YES**.
9. In the “Port” (**PORT**) field, enter a port number based upon which twin-ax address the IPDS printer is assigned. Use the following table to assign the port:

| Twin-ax Address | Line1 Port # |
|-----------------|--------------|
| 0 | 5001 |
| 1 | 5002 |
| 2 | 5003 |
| 3 | 5004 |
| 4 | 5005 |
| 5 | 5006 |
| 6 | 5007 |

For example, if the IPDS printer has a twin-ax address of 5, then the value to enter in the Port field would be 5006.

10. In the “Font” (**FONT**) field, enter an appropriate value such as **11**.
11. In the “Form Feed” (**FORMFEED**) field, enter ***AUTOCUT**.

-
12. In the “Activation Timer” (**ACTTMR**) field, enter ***NOMAX**. This will cause the AS/400 host to wait indefinitely for a response to an activation request.
 13. In the “Remote Location” (**RMTLOCNAME**) field, enter the TCP/IP address of the LanRPC+. You may also enter the host name if you used the optional CFGTCP command to create a TCP/IP Host Table entry.
 14. In the “User-Defined Object” (**USRDFNOBJ**) field enter the object name you entered in the PSF Configuration (PSFCFG) field when setting up AFP (section 3.1.6.1, step 3 above). This is the PSF configuration object that is used internally by the AS/400 when referring to the LanRPC+.
- Leave the “Library” blank unless you know its name.
- Enter *PSFCFG as the “Object Type”.

Configuring V4R2 and Above

AFP for V4R2 and Above

1. At the AS/400 command line, enter the command **CRTPSFCFG**.
2. Press Enter or F4 to display the keywords.
3. In the “PSF Configuration” (**PSFCFG**) field, enter the name of the object. Remember this name as it will also be entered in the User-Defined Object (USRDFNOBJ) field in the printer device description that will be created in the next section.
4. In the “IPDS Pass Through” (**IPDSPASTHR**) field, enter ***NO**.

You may want to set this value to *YES if you have applications that generate SCS or IPDS data streams that are printed to an AFP printer if the following uses apply:

 - 1) An application like Business Graphics Utilities, GDDM, or Virtual Print that does not support AFPDS is used; or
 - 2) The SCS or IPDS application does not contain any reference to overlay page segments or host font character sets. Certain limitations and other configuration considerations are discussed in IBM's *Printer Device Programming Version 5 (SC41-5713-05)* publication.
5. In the “Activation Release Timer” (**ACTRLSTMR**) field, enter ***NORDYF**. This will cause PSF/400 to print all spooled files with a status of RDY before releasing the session (which does not terminate the writer).
6. In the “Release Timer” (**RLSTMR**) field, enter ***SEC15**. This parameter should be set to a value less than the timeout value on the printer. This is the time PSF/400 will maintain a session with the printer while there are no spooled files with a status of RDY.
7. In the “**Automatic Session Recovery**” field, enter ***YES**. This causes the PSF/400 to automatically attempt to resume printing when a session has been unexpectedly ended.
8. In the “**Acknowledgement Frequency**” field, enter “**10**”. This value is the frequency, in number of pages that the AS/400 sends an acknowledgement request to the printer for status of pages printed. This value is used to determine where to restart printing after a connection has been lost and re-established. However, if acknowledgement frequency requests are made with great frequency, such as once per page, performance degradation may be noticed.
9. Optional selection – In the “Page Size Control” field, enter ***YES**. This causes PSF/400 to set the page size (forms) in lieu of using the printer's default size. Generally this parameter is used when a 4028 printer emulation is selected.
10. Optional Selection – In the “Edge Orient” field, enter ***YES**. When the page rotation value of a spooled file is *COR or *AUTO and the system rotates the output, 90 degree rotation is normally used. When this parameter is *Yes, PSF/400 rotates the output 270 degrees instead of 90 degrees.
11. APPC and TCP/IP Retry Count – In the “Retry” field, enter ***NOMAX**. This causes the host to continually attempt to reconnect to the device.

PSF/400 for V4R2 and Above

The following instructions are used to create a printer device description:

1. At the AS/400 command line, enter the command **CRTDEVPRT**.
2. Press the F4 key to display the keywords.
3. In the “Device Description” (**DEV D**) field, enter the name of the printer. The name may be comprised of the letters A-Z and numerals 0-9, must begin with a letter, with a maximum of 10 characters allowed.
4. In the “Device Class” (**DEVCLS**) field, enter ***LAN**.
5. In the “Device Type” (**TYPE**) field, enter ***IPDS**.
6. In the “Device Model” (**MODEL**) field, enter **0**.
7. In the “LAN Attachment” (**LANATTACH**) field, enter ***IP**. Then press F10.
8. In the “Advanced Function Printing” field, enter ***YES**.
9. In the “Port” (**PORT**) field, enter the port number based upon which twin-ax address the LanRPC+ the IPDS printer is attached. Use the following table to assign the port:

| Twin-ax Address | Line1 Port # |
|------------------------|---------------------|
| 0 | 5001 |
| 1 | 5002 |
| 2 | 5003 |
| 3 | 5004 |
| 4 | 5005 |
| 5 | 5006 |
| 6 | 5007 |

For example, if the IPDS printer has a twin-ax address of 5, then the value to enter in the Port field would be 5006.

10. In the “Font” (**FONT**) field, enter an appropriate value such as **11**.
11. In the “Form Feed” (**FORMFEED**) field, enter ***AUTOCUT**.
12. In the “Activation Timer” (**ACTTMR**) field, enter ***NOMAX**. This will cause the AS/400 host to wait indefinitely for a response to an activation request.
13. In the “Remote Location” (**RMTLOCNAME**) field, enter the TCP/IP address of the LanRPC+. You may also enter the host name if you used the optional CFGTCP command to create a TCP/IP Host Table entry.
14. In the “User-Defined Object” (**USRDFNOBJ**) field, enter the object name you entered in the PSF Configuration (PSFCFG) field when setting up AFP (section 3.1.7.1, step 3 above). This is the PSF configuration object that is used internally by the AS/400 when referring to the LanRPC+.

Leave the “Library” blank unless you know its name.

Enter ***PSFCFG** as the “Object Type”.

Verifying the IPDS Configuration on the AS/400

To test that the AS/400 and the LanRPC+ are connected and communicating, ping the LanRPC+ from an AS/400 workstation with the following command:

PING 'TCP/IP ADDRESS' or PING HOST NAME

'TCP/IP Address' is the address of the LanRPC+ (be sure to include the single quote marks around the address). Host name is the optional name you may have defined for the LanRPC+ if you created an optional TCP/IP Host Table entry. If the pings are successful, vary on the printer's device description by typing this command (all on one line):

WRKCFGSTS *DEV *printer name*

To use PSF/400 to send IPDS files to the printer, start the writer by typing this command:

STRPRTWTR *printer name*

Configure the LanRPC+ Print Server

The process of configuring the LanRPC+ involves setting an IP address for the Print Server, selecting the appropriate protocol for communicating to the AS/400, iSeries or eServer i5 host, and setting up the Print Server to use the appropriate protocols. Depending upon the protocol selected, there also may be a need to do some setup on the host (refer to the Configuring the AS/400, iSeries or eServer i5 section).

Setting the General Information and IP Address

1. Run the I-O Configuration Utility by clicking on Start | Programs, navigate to the I-O Configuration Utility Group, and click on the I-O Configuration Utility option.

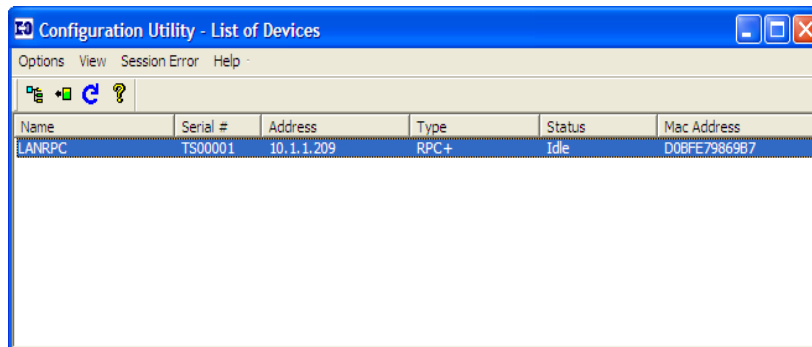

2. In the List of Devices, you will find an entry with a type of RPC+ and the serial number for the LanRPC+ that you want to configure. If there is no entry, click on the Rescan icon  to refresh the list. Double click on the desired LanRPC+.



NOTE: IF THE LANRPC FAILS TO ACQUIRE A DHCP ASSIGNED IP ADDRESS, SEE TROUBLESHOOTING NOTES ON PAGE 51 FOR CONFIGURING A NEW IP ADDRESS.

3. On the Controller Information tab:

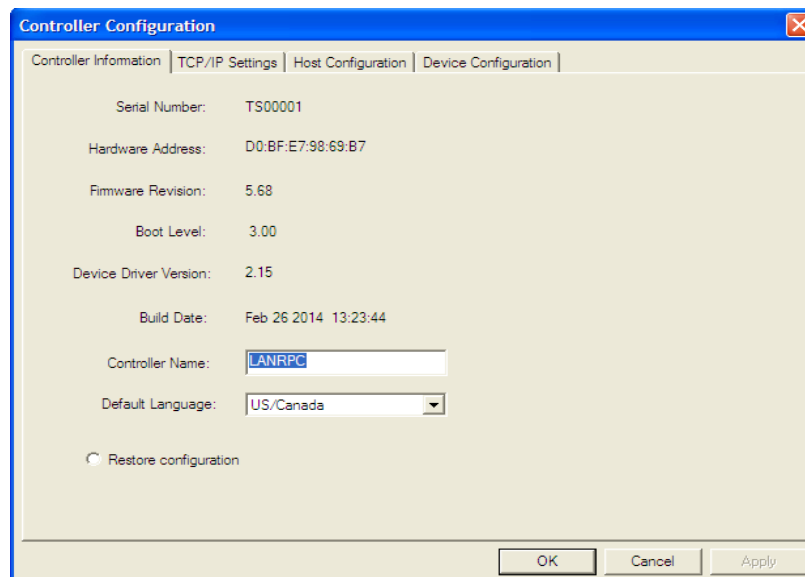

- a. In the **Controller Name** field, enter the name that will be used on the I-O Configuration Utility's List of Devices screen. This name is used only with the I-O Configuration Utility.
- b. In the **Default Language** field, select the default language for your printer. There is an option to override the default language in the Device Configuration tab, however due to a limitation of memory, this feature is currently limited to the default language selected in the Controller Information tab.
- c. By selecting the **Restore Configuration** radio button, you can restore a previous configuration file if for some reason the LanRPC+ configuration was lost, corrupted, or factory defaults were restored. Once you have configured the Print Server, it is recommended that you save the configuration file as a backup by going to Explore | Program Files | I-O Configuration and save the C819.....cfg file (819.... being the serial number of the LanRPC+).

To restore the configuration file, copy and paste the backup C819.....cfg file into the I-O Configuration folder replacing the current file. Open the configuration of the LanRPC+ and select the Restore Configuration radio button, click OK and Yes on the Reset. **DO NOT** make any changes to any of the fields, otherwise the configuration file will change to reflect that change and won't restore the correct configuration.

4. On the TCP/IP Settings tab, assign the IP address for the LanRPC+:

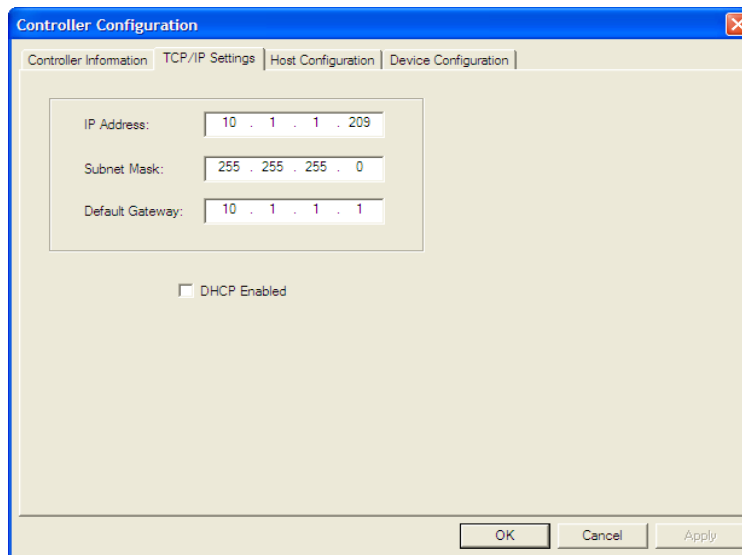

The screenshot shows the 'Controller Configuration' dialog box with the 'TCP/IP Settings' tab selected. The dialog has four tabs: 'Controller Information', 'TCP/IP Settings', 'Host Configuration', and 'Device Configuration'. The 'TCP/IP Settings' tab contains three text input fields: 'IP Address' with the value '10 . 1 . 1 . 209', 'Subnet Mask' with the value '255 . 255 . 255 . 0', and 'Default Gateway' with the value '10 . 1 . 1 . 1'. Below these fields is a checkbox labeled 'DHCP Enabled' which is currently unchecked. At the bottom right of the dialog are three buttons: 'OK', 'Cancel', and 'Apply'.

- a. To have the IP address automatically assigned by DHCP, select the DHCP Enabled check box, then skip to the next section entitled Select the Host Communication Protocol.
- b. Otherwise uncheck the DHCP Enabled check box to assign the IP address manually.
 - i. In the IP Address field, enter the TCP/IP address of the LanRPC+.
 - ii. In the Subnet Mask field, enter the subnet mask of the LanRPC+.
 - iii. In the Default Gateway field, enter the IP address of the router or gateway serving the LanRPC+.

Select the Host Communication Protocol

Three protocols are available to connect to the AS/400, iSeries or eServer i5 host – two TCP/IP protocols (TN5250e and AnyNet) and IBM's SNA (**currently SNA is not functional**). All protocols are auto configuring on the host. The LanRPC+ will support up to four hosts. On the first host, either one of the two protocols may be selected. Choose the protocol based upon the type of device that is being attached.



NOTE: AFTER SELECTING THE PROTOCOL, GO TO THE APPROPRIATE SECTION IN THIS CHAPTER FOR INSTRUCTIONS ON COMPLETING THE CONFIGURATION OF THE LANRPC+.

- **TN5250e** is a routable protocol. This means that it can be used at remote locations (or where there is a router between the Print Server and the host). TN5250e is the easiest protocol to setup for SCS printers. Using TN5250e for configuring an IPDS Printer requires you to have PSF/400 installed and for you to manually configure the IPDS Printer on the iSeries Host.

Non-IPDS Printers are auto configured on the host as 3812-1 SCS page printers. The Print Server will customize the data stream to the attached twin-ax printer's capability removing SCS commands the printer cannot support. This allows printers like a 4214, 5224, etc. to be attached. However, TN5250e is limited in that it does not support posting the dot-matrix form alignment message (see Tip below) as well as the IBM dot-matrix functions of backspace, bold, underscore or overstrike.



TIP: TN5250E IS RECOMMENDED WHEN THE PRINTER IS AN SCS PRINTER, IS A 3812-1 LASER PRINTER OR DOT-MATRIX PRINTER NOT AFFECTED BY THE BACKSPACING LIMITATIONS. ALIGNMENT MESSAGES CAN BE OBTAINED BY CHANGING THE FORM FEED PARAMETER IN THE PRINTER CONFIGURATION TO *CONT.

- **AnyNet** is actually SNA encapsulated in TCP/IP and is a routable protocol. It is more difficult than TN5250e to initially configure, but has the advantage of reporting to the host the twin-ax device's native model so that the actual device will be auto configured on the host. AnyNet fully supports all SCS and IPDS printers.



TIP: ANYNET IS THE RECOMMENDED PROTOCOL TO USE WHEN CONNECTING IPDS PRINTERS (WHERE A LICENSE FOR PSF/400 IS NOT AVAILABLE) OR WHERE THERE ARE IBM SCS DOT-MATRIX PRINTERS PRINTING APPLICATIONS THAT REQUIRE FEATURES NOT SUPPORTED BY TN5250E.

- **SNA** is IBM's most robust protocol. However, SNA cannot be routed. (**Currently SNA is not supported on the LanRPC+**). Like AnyNet, SNA is more difficult than TN5250e to initially configure. This protocol can only be used when the LanRPC+ is located within the same Ethernet link as the host (there cannot be a router between them). Like AnyNet, the twin-ax device's actual model will be auto configured on the host. SNA also does not have the limitations of TN5250e in that it fully supports all SCS and IPDS printers.



TIP: SNA IS THE RECOMMENDED PROTOCOL TO USE FOR LOCAL CONNECTIONS.

Configure the LanRPC+ to Use TN5250e



TIP: USE THIS PROTOCOL IF THE PRINTER TO BE ATTACHED TO THE LANRPC+ IS: AN SCS PRINTER THAT DOES NOT NEED TO UTILIZE THE BACKSPACE, UNDERSCORE, BOLD OR OVERSTRIKE FUNCTIONS, OR IT IS IPDS AND YOU HAVE A LICENSE FOR PSF/400. AN IPDS PRINTER WILL REQUIRE MANUALLY CONFIGURING A PSF OBJECT AND THE IPDS PRINTER. ALIGNMENT MESSAGES FOR AN SCS PRINTER CAN BE OBTAINED BY CHANGING THE FORM FEED PARAMETER IN THE PRINTER CONFIGURATION TO *CONT.

1. After setting up the Print Server's general information and the IP address, select the **Host Configuration tab**.

The screenshot shows the 'Controller Configuration' dialog box with the 'Host Configuration' tab selected. It contains four host configuration panels (Host 1 through Host 4). Host 1 is configured with 'Telnet 5250' as the connection type and the IP address '10.1.1.203'. Hosts 2, 3, and 4 are currently set to 'None'. Below the host panels is a 'Telnet Options' section with a 'Default Device Name' field containing 'RPC', a checked checkbox for 'Disable Connection Status Report', and an unchecked checkbox for 'Disable Auto Creation of Devices'. At the bottom are 'OK', 'Cancel', and 'Apply' buttons.

- a. For each host to be configured select the TN5250e radio button.
- b. In the Host IP Address field, enter the IP address of the AS/400, iSeries or eServer i5 host.



NOTE: IN GENERAL, A HOST SHOULD ONLY BE ASSIGNED ONE TIME. HOWEVER, THE SAME HOST MAY BE USED IN HOST 1 WITH ANYNET AND AGAIN IN HOST 2 WITH TN5250E.

- c. In the Telnet Options section, **enter up to six characters** in the Default Device Name field that will become the first part of the name the Print Server will use when assigning a name to each device. If a name is not entered, the Print Server will assume the name RPCxx, the xx being a random 2 digit number.

When the Print Server assigns a name, it will take the value in this field, and add a "P" indicating the device is a printer. This will be followed by a "1", indicating the line the device is attached to. The next digit is the twin-ax address of the device. For example, if "TEST" was entered into this field, and there is a printer connected with the twin-ax address of 4, the Print Server would assign the name of "TESTP14".

The LanRPC+ will support up to four printer sessions, one session for each host. If two hosts are configured, only two printer sessions will be available – one on each host. The Telnet device name will be the same on each host.

2. On the **Device Configuration tab**, you can manually enter the Telnet device name for the printer by overriding the Print Server's automatically assigned name. For renaming the device, do the following:

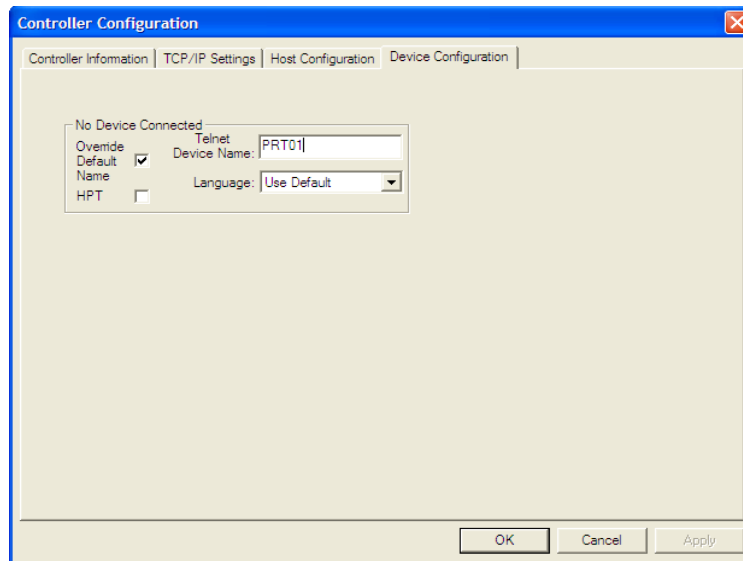

- a. If you want to override the Telnet Default Device Name the LanRPC+ assigned or the name you entered into the Default Device Name on the Host Configuration Tab, check the box for Override Default Name. In the Telnet Device Name field, enter the name the host will use for this device.



NOTE: PRIOR TO THE HOST CONFIGURING ANY DEVICE, YOU CAN CHECK THE OVERRIDE DEFAULT NAME BOX AND ENTER THE NAME YOU WANT THE HOST TO CONFIGURE. AFTER THE RESET, THE DEVICE WILL BE CONFIGURED AFTER THE DEVICE BECOMES ACTIVE, SUCH AS CONNECTING AND POWERING ON THE DEVICE.

- b. Currently the Default Language set in the Controller Information tab cannot be overridden by the Language selection for the device.
3. When all settings on all the tabs have been completed, **click OK**. You will be presented with a confirmation screen, **click Yes to save the settings** and the LanRPC+ will reset.
4. After the LanRPC+ restarts, the printer will be created. Be patient as it takes the Print Server a couple of minutes to reset and come active. It may take the host a few moments to create the printer as well.

Configure the LanRPC+ to Use AnyNet



TIP: USE THIS PROTOCOL IF THERE IS AN IPDS PRINTER TO BE SUPPORTED WITHOUT A LICENSE FOR PSF, OR IF THERE IS AN IBM DOT-MATRIX PRINTER THAT REQUIRES THE BACKSPACE, UNDERSCORE, BOLD OR OVERSTRIKE FUNCTIONS.

1. After setting up the Print Server's general information and the IP address, select the **Host Configuration tab**.

The screenshot shows the 'Controller Configuration' dialog box with the 'Host Configuration' tab selected. It contains four host configuration sections (Host 1, Host 2, Host 3, Host 4) and a 'Telnet Options' section. Host 1 is the active host, with 'AnyNet' selected for its connection type. The IP address is 10.1.1.203, the control point name is S100AA1G, the network ID is APPN, and the interface control point name is LRPC. The Telnet options are 'Disable Connection Status Report' (checked) and 'Disable Auto Creation of Devices' (unchecked). Buttons for OK, Cancel, and Apply are at the bottom.

2. Select the AnyNet radio button.
3. In the Host IP Address field, enter the IP address of the AS/400, iSeries or eServer i5 host.
4. In the Host Control Point Name field, enter the Local Control Point Name for the AS/400, iSeries or eServer i5 host.
5. In the Host Network ID field, enter the Local Network ID name.
6. In the Interface Control Point Name field, enter a name for the LanRPC+. The name must meet the following requirements:
 - The name can be no shorter than two characters and no longer than eight characters in length.
 - The name must start with an alpha character (A-Z).
 - The name must contain only alpha-numeric characters (A-Z, 0-9).
 - The first four characters must uniquely identify the LanRPC+, since the Print Server will automatically create a printer on the host using the first four characters of this name followed by five additional host assigned characters.

7. On the **Device Configuration** tab, the Language field, **will not** override the default language selected on the Controller Information tab. This is a feature, which we hope to be able to rectify in the future.

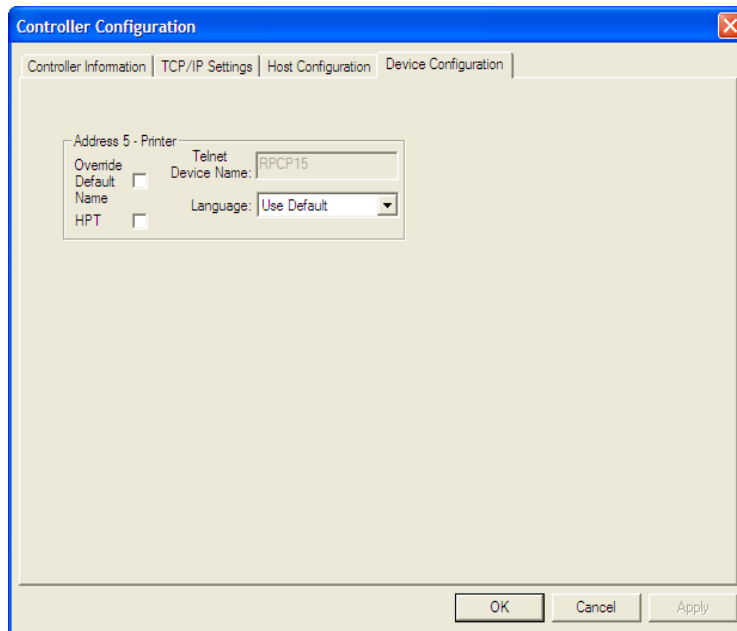

8. When settings have been completed on all the tabs, **click OK**. **Click Yes** to save the settings and the Print Server will reset.
9. After the Print Server resets, the printer will auto configure on the host. Be patient as it takes the LanRPC+ a couple minutes to reset and come active. It may take the host a few moments to create the printer.

The following devices will now automatically be created on the host:

- An APPC Controller with the name assigned as the "Interface Control Point".
- A 5494 Controller with the first five characters of the "Interface Control Point" name followed by the identifier RMT.
- A printer will be configured when the LanRPC+ is reset. The name will follow the format of ABCDPRT0X where ABCD are the first four characters of the Interface Control Point Name, PRT indicating a printer, 0 indicating line 1 and X will be the twin-ax address.

Configure the LanRPC+ to Use SNA

Currently SNA is not supported on the LanRPC+. (Use the AnyNet protocol if SNA features are required).



TIP: USE THIS PROTOCOL ONLY IF THE LANRPC+ AND THE HOST ARE WITHIN THE SAME ETHERNET LINK (IE. THERE ARE NO ROUTERS BETWEEN THE PRINT SERVER AND THE HOST).

1. After setting up the Print Server's general information and the IP address, select the **Host Configuration** tab.

The screenshot shows the 'Controller Configuration' dialog box with the 'Host Configuration' tab selected. It contains four host configuration panels (Host 1 to Host 4). Host 1 is the active host, showing 'Host Connection Type' set to 'SNA'. Other fields for Host 1 include 'Host IP Address', 'Host Local Adapter Address' (02:00:00:0E:1A:0F), 'Host Control Point Name' (S100AA1G), 'Host Network ID' (APPN), and 'Interface Control Point Name' (SNARPC). Below the host panels are 'Telnet Options' with a 'Default Device Name' of RPC35 and checkboxes for 'Disable Connection Status Report' (checked) and 'Disable Auto Creation of Devices' (unchecked). Buttons for 'OK', 'Cancel', and 'Apply' are at the bottom.

2. In the host Adapter Address field, enter the Local Adapter Address for the line this Print Server will be connected on. Make certain the address is entered in the format of XX:XX:XX:XX:XX:XX.
3. In the Host Control Point Name field, enter the Local Control Point Name for the AS/400, iSeries or eServer i5 host.
4. In the Host Network ID field, enter the Local Network ID name.
5. In the Interface Control Point Name field, enter a name for the LanRPC+. The name must meet the following requirements:
 - The name can be no shorter than two characters and no longer than eight characters in length.
 - The name must start with an alpha character (A-Z).
 - The name must contain only alpha-numeric characters (A-Z, 0-9).
 - The first four characters must uniquely identify the LanRPC+, since the Print Server will automatically create the printer on the host using the first four characters of this name followed by five additional host assigned characters.

6. On the **Device Configuration** tab, the Language field, **will not** override the default language selected on the Controller Information tab. This is a feature, which we hope to be able to rectify in the future.

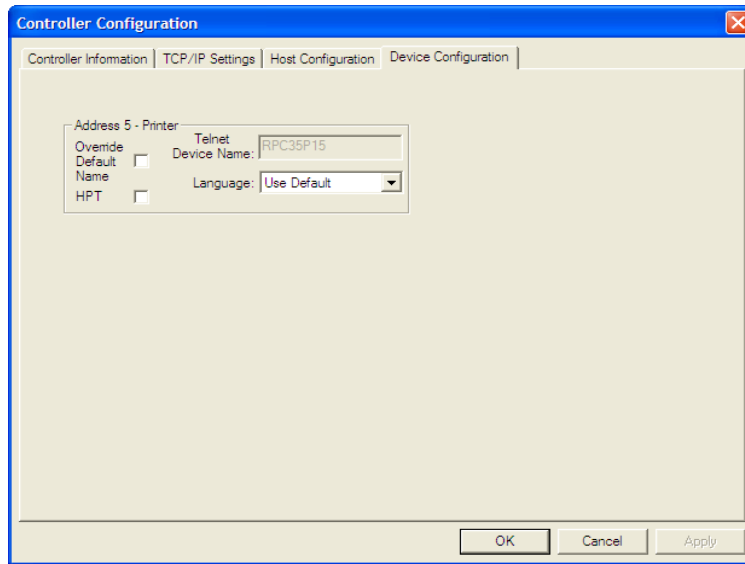

7. When settings have been completed on all the tabs, **click OK**. **Click Yes** to save the settings and the LanRPC+ will reset.
8. After the LanRPC+ resets, the printer will auto configure on the host. Be patient as it takes the Print Server a couple minutes to reset and come active. It may take the host a few moments to create the printer.

The following devices will now be automatically created on the host:

- An APPC Controller with the name assigned as the "Interface Control Point".
- A 5494 Controller with the first five characters of the "Interface Control Point" name followed by the identifier RMT.
- A printer will be configured when the LanRPC+ is reset. The name will follow the format of ABCDPRT0X where ABCD are the first four characters of the Interface Control Point Name, PRT indicating a printer, 0 indicating line 1 and X will be the twin-ax address.

Configure the LanRPC+ for IPDS Printing via PPR/PPD

When configuring IPDS printers on the host via PPR/PPD, use the Telnet 5250 protocol for the Host configuration.

When an IPDS printer is attached to a twin-ax cable, it is given a twin-ax address. This address along with the line number the printer is attached to; Line 1 is used to configure the host's PSF object and printer device description. See configuration instructions on page 22 and 23.

LanRPC+ Operation

Sharing a Printer with Multiple Hosts

When a printer is idle, the Print Server will report to all hosts that the printer is available. The first host to send a job to the printer will get exclusive use of the printer until the writer is stopped. While the host's writer is active, all other hosts are told the printer is not available. When the active writer is ended, all hosts are told (after a short time-out) that the printer is now powered-up and available.

TN5250e Operation

If a printer does not auto configure, then the host has not accepted the request to connect. This can be caused by the following conditions:

- Incorrect IP address for the host – reenter the proper IP address.
- Incorrect IP address of the Print Server (another device may have the same address) – reenter a valid IP address.
- The host may not be set for auto-configuration – the system administrator will need to turn this on, or manually configure a device.
- The host may not have enough virtual device sessions available – the system administrator will need to use the CHGSYSVAL command to increase the number of available sessions.
- The host may believe there is another device with the same name and IP address already active – the system administrator will need to vary off the device and end the TCP/IP session (see Troubleshooting for details on how to handle this issue).



TIP: SEE TROUBLESHOOTING FOR MORE INFORMATION ON CONNECTION ISSUES.

Starting a Printer Session

The Printer session will start automatically after the LanRPC+ has reset and made a host connection.



NOTE: THE FIRST TIME THE PRINT SERVER IS CONFIGURED (OR AFTER THE PRINT SERVER HAS HAD THE FACTORY DEFAULTS RESTORED), ONE PRINTER SESSION WILL BE CONFIGURED ON EACH CONFIGURED HOST.

When the printer session has completed the startup process and has established a connection with the host, a Printer Connection Status message will be generated and sent to the printer. It will look like this:

```
AS/400 Host Communication Status:
Connection attempt succeeded
Host system S101256R
Printer name TNPRT00
Status code I902 - Session successfully started
```

The status code (I902) shown in the above example is the normal code indicating successful host communication.

If the printer session is not able to establish a connection to the host, the Printer Connection Status message will still be printed, but with a different status code and brief explanation. Refer to the Troubleshooting chapter for possible solutions to connection errors.



NOTE: IF YOU DO NOT DESIRE TO HAVE THE CONNECTION STATUS PAGE PRINT OUT, IT CAN BE DISABLED BY GOING INTO THE HOST CONFIGURATION TAB AND CHECK THE BOX FOR DISABLE CONNECTION STATUS REPORT AT THE BOTTOM IN TELNET OPTIONS.

Re-Connect a Session

There are several methods of reconnecting a TN5250e session to the host:

- The LanRPC+ will automatically attempt to reconnect with the host every five minutes.
- Reset the LanRPC+ from either the Configuration Utility or by cycling power on the Print Server.
- Power the printer off and back on again.

Disconnect a Session

In normal use the LanRPC+ should never be powered down. In the unlikely event the Print Server is to be powered down, press and release the power button. After a minute or two, the power down process will power off the unit. When the LanRPC+ is powered up again, any printer that is powered on will reconnect to the host.



NOTE: IF POWER IS ACCIDENTLY CYCLED ON THE LANRPC+, THE HOST WILL CLOSE THE TELNET SESSION AND RE-ESTABLISH THE CONNECTION AFTER THE PRINT SERVER REBOOTS.

How Telnet Names a Device

In the I-O Configuration Utility, a unique Telnet device name is assigned to the printer by default. This is done in one of three ways:

- The LanRPC+ automatically defaults with a Telnet Device Name that auto fills the Telnet Options box on the Host Configuration screen in the I-O Configuration Utility. This default name is RPCxx with the xx being a randomly generated number.
 - The LanRPC+ will automatically assign a name based upon the Default Telnet Device Name that is manually entered in the Telnet Options box on the Host Configuration screen in the I-O Configuration Utility.
- Or
- Manually enter a unique name for the printer on the Device Configuration screen by selecting the Override Default Name in the I-O Configuration Utility.



TIP: USE THE DEFAULT NAMING PROCESS TO HAVE THE LANRPC+ AUTOMATICALLY ASSIGN A NAME, THEN FOR A SPECIFIC DEVICE, OVERRIDE THE AUTOMATICALLY CREATED NAME.

Each host will use the same name for the printer. For example, if there was a 3812-1 printer using the Twin-ax address of 1, and the Telnet device name assigned in the I-O Configuration Utility was "ACCNTG", then this printer would be known as "ACCNTG" on each host.

When the LanRPC+ is configured for the first time, each defined host will create a 3812-1 page printer device. This means the printer will support up to four different hosts.



NOTE: SHARING A PRINTER USING THE SAME NAME WITH MULTIPLE HOSTS IS ONLY AVAILABLE WHEN USING THE TN5250E PROTOCOL. IF ANYNET IS USED FOR THE FIRST HOST, AND TN5250E IS USED FOR THE SECOND, THIRD AND FOURTH HOSTS, ANYNET ASSIGNS ITS OWN UNIQUE DEVICE NAME WHILE THE TN5250E HOSTS WILL USE THE SAME TELNET DEVICE NAME.

AnyNet Operation

Starting a Printer Session

After the LanRPC+ has been configured, the Print Server will cycle through a restart process. During this process the Print Server is connecting to the host and the host is creating the devices. A printer session will start automatically as the host makes the connection.



NOTE: THE FIRST TIME THE LANRPC+ IS CONFIGURED (OR AFTER THE PRINT SERVER HAS HAD THE FACTORY DEFAULTS RESTORED), THE PRINTER SESSION WILL BE CONFIGURED ON EACH HOST.

If the printer does not get created or if created, but does not vary on, then the host has not accepted the request to connect. This can be caused by the following conditions:

- Incorrect IP address of the LanRPC+ (another device may have the same address) – re-enter a valid IP address.
- Incorrect host information may have been entered on the LanRPC+'s Host Configuration screen– verify that the host IP address, Host Network ID, Host Control Point Name, and Remote Control Point Name are entered correctly.
- The host may not be set for auto-configuration or auto-remote – the system administrator will need to turn these on.
- The host may not have enough virtual device sessions available – the system administrator will need to increase the number of available sessions.



TIP: SEE TROUBLESHOOTING FOR MORE INFORMATION ON CONNECTION ISSUES.

Re-Connect a Session

There are several methods of reconnecting a session to the hosts:

- Cycle power on the Printer.
- At the host, vary off the printer and then back on, then cycle power on the printer.
- Cycle power on the LanRPC+.

Disconnect a Session

In normal use the LanRPC+ should never be powered down. In the unlikely event that the Print Server is to be powered down, press and release the power button, then power down the printer. The LanRPC+ will go through its power down process which takes a minute or two.



CAUTION: IF POWER IS ACCIDENTLY CYCLED ON THE LANRPC+, THE HOST MAY STILL HAVE OPEN SESSIONS AND IT MAY TAKE SEVERAL MINUTES TO RECONNECT.

How AnyNet Names Devices

After the LanRPC+ has been configured and restarted, the following devices will automatically be created on the host:

- An APPC Controller with the name assigned as the “Interface Control Point”.
- A 5494 Controller with the first five characters of the “Interface Control Point” name followed by the identifier RMT.
- A printer that is attached and powered on at the time the Print Server was configured and reset. The name will follow the format of ABCDPRTXX where ABCD are the first four characters of the Interface Control Point Name. PRT indicating a printer. XX will be a hexadecimal value assigned by the host based on the line and the twin-ax address.

The host will configure the XX value in the following manner:

- Hex values 00 to 06 represent Line 1 and address 0-6.

SNA Operation

Currently SNA is not functional on the LanRPC+. For applications that require true printer emulation, use the AnyNet Protocol.

IPDS Operation via PPR/PPD

The LanRPC+ automatically passes all communication and data streams to and from the IBM host and the IPDS printer. No operator action is required at the LanRPC+.

Troubleshooting

This chapter contains solutions for problems you may encounter while using the product. If a problem persists after implementing the solutions provided here, or if a problem is not listed here, please contact your dealer or I-O Corporation can be contacted at 801-973-6767 or by email at support@iocorp.com.

Please have the following information available when requesting assistance:

- Model number
- Version number of the firmware and driver
- Version number of the I-O Configuration Utility
- Serial number of the LanRPC+ (found on the back label of the logic unit)
- Version of operating system on the AS/400, iSeries or eServer i5system
- Concise description of problem
- Summary of events and actions that occurred just prior to the failure
- Model number of the printer that is attached to the LanRPC+
- Information on which protocol the LanRPC+ is using for its configuration

General Error Conditions

| <i>Problem</i> | <i>Solution</i> |
|--|--|
|  <ul style="list-style-type: none"> • No power to the LanRPC+ (Power LED and Line LED's are off) | <ul style="list-style-type: none"> ✓ The LanRPC+ uses a 12vdc – 5a external power supply, which may have gone bad. Check the power supply for power. If the power supply has 12vdc output, there may be a connection issue with the power connector. Contact I-O Corporation for assistance. 801-972-1446 <hr/> <p>CAUTION: PLUGGING IN A DIFFERENT POWER SUPPLY COULD DAMAGE THE LANRPC+.</p> <hr/> |
| <ul style="list-style-type: none"> • The host does not configure a printer. | <ul style="list-style-type: none"> ✓ There is no communication with the host. <ul style="list-style-type: none"> • The host is not operating. • The LanRPC+ is not operating. • Check all cable connections, routers, etc. for proper connection. • Auto-configure is not enabled on the host. • The printer and LanRPC+ are not communicating. |
| <ul style="list-style-type: none"> • On the Device Configuration screen in the Configuration Utility, I see a device, but the host does not configure a printer. | <ul style="list-style-type: none"> ✓ Check the following: <ul style="list-style-type: none"> • Verify the IP address of the host is entered correctly in the I-O Configuration Utility. • Make sure there are no other devices in the network using the same IP address as the LanRPC+. • Answer any host messages. • If using AnyNet, vary the device off and back on, then cycle power on the LanRPC+. • If using SNA, this protocol is not functional with the LANRPC+. Change the protocol to AnyNet. |

- The host assigns a 3812-printer device with a name of RPCxxPyy (where xx and yy are 2-digit numbers).
 - The writer is in a writing status, but no printing is occurring and there are no messages on the host.
 - The printer is in a Vary On Pending state.
- If using Telnet, end the Telnet session. At a command line on the host, enter "netstat", select the Work with TCP/IP Connection Status option, press ENTER. (You may also use the "wrktcpsts *dev [device name]" command.) Scroll until an entry for the IP address of the LanRPC+ is found. Select the option to end the session. Cycle power on the printer.
 - ✓ If the Telnet Default Device Name is left blank when configuring the Host session and you do not override the default device name in the Device Configuration screen, the LanRPC+ will default with RPCxx and the host will create a 3812 device, but will give the printer the name of RPCxxPyy, with xx being a random 2-digit number. P for printer and the first "y" is the line number and the second "y" is the printer address.
 - To correct the problem, using the I-O Configuration Utility, check the Override Default Name in the Device Configuration tab and enter a specific printer name.
 - ✓ This usually occurs when TN5250e communication has been lost with the host.
 - Re-establish the session by doing the following:
 1. Vary off the printer. At a command line on the host, enter "wrkdevd [device name]", press ENTER. Select the work with status option 8, then vary off the device.
 2. Cycle power on the printer.
 - ✓ This usually occurs when TN5250e communication has been lost with the host.
 - Re-establish the session by doing the following: Vary off the device and end the Telnet session:
 1. To vary off a device, at a command line on the host, enter "wrkdevd [device name]", press ENTER. Select the work with status option, then vary off the device.
 2. To end the Telnet session, at a command line on the host, enter "netstat", select the Work with TCP/IP Connection Status option 3, press ENTER. (You may also use the "wrktcpsts *dev [device name]" command.) Scroll until an entry for the IP address of the LanRPC+ is found (there will be one entry for Telnet or two for Anynet). Select the option to end the session(s).

- The printer session has ended on the AS/400 host after a period of inactivity.

- ✓ The host has a timeout value that can be set to terminate any Telnet printer session. Setting this value to a longer timeout will allow the printer session to remain connected for a longer period. However, this longer timeout will also allow an unattended Telnet display session to remain open for a longer period and may create a security issue.

To change the Telnet inactivity timer, follow these steps:

1. Using the host CFGTCP command, select menu option 20, Configure TCP/IP Applications.
2. Select menu option 11, Configure Telnet.
3. On the next screen, select menu option 12, Inactive Job Time Out.
4. Change the QINACTITV value to a longer value, or use *NONE to deactivate the inactivity timeout.

- The host gets an error message indicating the printer has received invalid data and that the IBM dot-matrix printer will not bold, backspace, overstrike or underscore when using TN5250e.

- ✓ TN5250e does not support dot-matrix backspace functions.
- Change the protocol used to connect to the host to AnyNet.

General LanRPC+ Status Messages

The following messages appear on the Status Session Error | Controller Status screen in the I-O Configuration Utility:

| Message | Solution |
|--|--|
| <ul style="list-style-type: none"> • 0: Session status is normal. | <ul style="list-style-type: none"> ✓ This status means that a printer has been recognized on the twin-ax cable, and there is currently an active host communication session. |
| <ul style="list-style-type: none"> • 1: Device not connected. | <ul style="list-style-type: none"> ✓ No device is responding to polling on the twin-ax address for this session. |
| <ul style="list-style-type: none"> • 2: Host not configured. | <ul style="list-style-type: none"> ✓ A printer has been recognized on the twin-ax cable, but the LanRPC+ is not attempting to start a host connection for this session because there is no host configured for the session. This condition can arise only if fewer than four hosts are included in the LanRPC+ configuration. |
| <ul style="list-style-type: none"> • 3: Host not active | <ul style="list-style-type: none"> ✓ A printer has been recognized on the twin-ax cable, and there is a host computer configured for this session, but at this time the Controller is telling the host that this printer is not available (powered-down) because the printer is currently in use by a different host. |
| <ul style="list-style-type: none"> • 4: Paper Out. | <ul style="list-style-type: none"> ✓ The printer is out of paper. |
| <ul style="list-style-type: none"> • 5: Printer Offline. | <ul style="list-style-type: none"> ✓ The printer is off line. |

TN5250e Host Communication Status Messages

The following messages appear on the Status Session Error | Controller Status screen in the I-O Configuration Utility:

| Message | Solution |
|--|---|
| <ul style="list-style-type: none"> • 301: Host is unreachable. | <ul style="list-style-type: none"> ✓ The LanRPC+ is currently unable to establish any TCP connection to this host on behalf of the attached printer. • The host for this session is not powered-up. Verify that the host is powered-up and operational. • TCP has not been started on the host computer. Verify that TCP/IP, including telnet, has been configured and started on the host computer. • The LanRPC+ was configured with the wrong IP address for this host. Check the configuration of the Print Server to be sure the IP address entered for the host computer is correct. • TCP/IP communication is not possible between the locations of the LanRPC+ and this host computer. Verify (as by pinging the host computer from a location near the LanRPC+) that IP communication is possible between the two locations on the network. Also check to see that network traffic from the LanRPC+'s location to that of the host computer is not excluded for telnet (normally port 23) by communication equipment such as a firewall. Take any steps required to make the path available. |
| <ul style="list-style-type: none"> • 302: No TCP session for this device. | <ul style="list-style-type: none"> ✓ The LanRPC+ has failed to make a TCP connection for this session. • The host computer considers a previous TCP connection for this session from this LanRPC+ to be still active. This situation may arise if the LanRPC+ has been shut down while a printer was powered on. Check the device status for this device on the host. If the host shows the device to be active while the Print Server is showing status code 302, and if you know that the device description is used only by this Print Server, vary the device off. Then retry the connection. • The device name (specified during the LanRPC+ configuration) for this session is in use on this host by some other remote device. Verify that the device name specified during configuration of the Print Server is not duplicated by any other device connected to this host. • The host shows an invalid status for this device. Verify that the host shows the device status as being either 'varied off' or 'vary on pending'. If device status is any value other than these, vary the device on or off. |

- | | |
|--|--|
| <ul style="list-style-type: none"> • 303: No TN5250 negotiation started by host. | <ul style="list-style-type: none"> ✓ The LanRPC+ has successfully established a TCP connection to the host for this session, but the host has not yet initiated TN5250 negotiations on the TCP connection. This condition should never last more than a few seconds. If this status lasts more than a few seconds at a time, it indicates a host computer malfunction or misconfiguration. Report the problem to the administrator of the host computer. |
| <ul style="list-style-type: none"> • 304: TN5250 session negotiation proceeding. | <ul style="list-style-type: none"> ✓ A TN5250e TCP connection for this session has been established with the host, and values for TN5250e parameters for the session are being negotiated by the host and the LanRPC+. <p>This is a normal but transient status that exists briefly during startup of the host session for the device. No action is required. A 304 status should be considered to be an indication that session startup is proceeding normally. If a session reaches the 304 state and does not move on to some other state within a few seconds, contact I-O support.</p> |
| <ul style="list-style-type: none"> • 305: TN5250 session negotiation aborted by host. | <ul style="list-style-type: none"> ✓ The LanRPC+ has successfully established a TCP connection to the host for this session, but negotiation of TN5250 parameters for the session was aborted at the request of the host computer. <p>This status should never be seen. If the LanRPC+ and the host computer successfully begin TN5250 negotiations, startup of the session should always complete successfully. Contact I-O support for help in resolving the problem.</p> |

TN5250e Printer Connection Status Message

The LanRPC+ reports the success or failure of an attempt to communicate with the host(s) by printing a brief connection status message on each attached printer.

The message will show whether the connection succeeded or not, the name of the AS/400, iSeries or eServer i5 host the printer session is connected to, the printer name, and the session status. (If there is no Host or printer name in the message it is because the host did not send the information.)

The connection status message will look somewhat like:

```
AS/400 Host Communication Status:
Connection attempt succeeded
Host system S101256R
Printer name TNPRT00
Status code I902 - Session successfully started
```

The status code (I902) shown in the above example is the normal code indicating successful host communication. The possible values of the status code and suggested actions to take for that status code are as follows:

| Message | Solution |
|---|---|
| <ul style="list-style-type: none"> 0101 — Host not responding to pings | <ul style="list-style-type: none"> ✓ This message usually indicates one of the following: <ul style="list-style-type: none"> TCP/IP has not been started on the host. The host's IP address has not been correctly entered in the I-O 5250 Printer's configuration on the thin client. The LanRPC+ has not been correctly connected to the LAN. |
| <ul style="list-style-type: none"> 0102 — Host rejected connect to Telnet port | <ul style="list-style-type: none"> ✓ The host answers pings, but rejects a TCP/IP connect attempt, probably because its Telnet server has not been started. |
| <ul style="list-style-type: none"> 0111 — Host Telnet session lost | <ul style="list-style-type: none"> ✓ Usually means that the printer has been varied off at the host, the host has gone down, or there has been a communication (e.g. router) failure. |
| <ul style="list-style-type: none"> 2777 — Damaged device description | |
| <ul style="list-style-type: none"> 8902 — Device not available | <ul style="list-style-type: none"> ✓ This code appears when the I-O 5250 Printer connection attempts to start a session for a printer whose name duplicates the name of a printer already active on the host. In many cases, this means that the LanRPC+ with an I-O 5250 Printer session has been powered-off and then powered back on within a few minutes. When the LanRPC+ with an active I-O 5250 Printer session is turned off, it takes the host about 10-20 minutes to determine that the TCP/IP sessions for the printers are no longer active. If the I-O 5250 Printer session is restarted while the host shows the old printer sessions is still active, requests for new sessions will be rejected with this code. <p>You can recover by doing one of the following:</p> <ul style="list-style-type: none"> Wait 10-20 minutes before trying to establish another printer session. At the host, manually terminate the old TCP/IP sessions. Avoid the problem by allowing the I-O 5250 Printer session to end its TCP/IP connection gracefully before powering the LanRPC+ off. Do this by powering-off the attached printer 2 minutes or more before closing the printer session. |
| <ul style="list-style-type: none"> 8906 — Session initiation failed | |
| <ul style="list-style-type: none"> 8907 — Session failure | |

- 8920 — Object partially damaged
- 8921 — Communications error
- 8922 — Negative response received
- 8925 — Creation of device failed
- 8928 — Change of device failed
- 8930 — Message queue does not exist
- 8935 — Session rejected
- 8940 — Automatic configuration failed or not allowed
- E001 — No Telnet printer support at host ✓ The operating system on the host supports only display (not printer) devices in Telnet sessions. Update your host to support TN5250e printer sessions.
- I902 — Session successfully started
- I904 — Source system at incompatible release

AnyNet Host Communication Status Messages

The following messages appear on the Status Session Error | Controller Status screen in the I-O Configuration Utility:

| Message | Solution |
|--|--|
| <ul style="list-style-type: none"> 99: No SNA session for device. | <ul style="list-style-type: none"> ✓ The LanRPC+ is able to communicate with the host computer, but the host has not started an SNA session for this device. • The device is varied off at the host. At the host computer, vary the device on. • No Controller description for this Print Server exists on the host computer. Enable auto-creation of Controller descriptions on the host, or manually create a Controller description. • No device description for this device exists on the host computer. Enable auto-creation of devices for this Print Server on the host, or manually create a device description for the device. |
| <ul style="list-style-type: none"> 401: Host is unreachable. | <ul style="list-style-type: none"> ✓ The LanRPC+ is currently unable to establish any TCP connection to this host on behalf of any attached printer. • The host for this session is not powered-up. Verify that the host is powered-up and operational. • TCP has not been started on the host computer. Verify that TCP/IP and AnyNet have been configured and started on the host computer. • The LanRPC+ was configured with the wrong IP address for this host. Check the configuration of the LanRPC+ to be sure that the IP address entered for the host computer is correct. • TCP/IP communication is not possible between the locations of the LanRPC+ and this host computer. Verify (as by pinging the host computer from a location near the LanRPC+) that IP communication is possible between the two locations on the network. Also check to see that network traffic from the LanRPC+'s location to that of the host computer is not excluded for AnyNet (port 397, TCP and UDP) by communication equipment such as a firewall. Take any steps required to make the path available. • This Print Servers AnyNet APPC Controller on the host computer is not varied on. Check the host's configuration to determine which AnyNet APPC Controller is selected to service this Print Server. Then verify that the APPC Controller is varied on. • The host's TCP/IP Host Table does not include an entry that identifies the LanRPC+ as an AnyNet location. Verify the appropriate Host Table entry exists. If there is no entry, create one as described in the User Guide. |

- 402: Waiting to attempt host connect.
 - ✓ The LanRPC+ currently has no connection to the host computer, and is not currently attempting to establish a connection.
 - The LanRPC's 5494 Controller description on the host computer is not varied on. Verify the Controller description on the host computer is varied on.
 - The LanRPC+ has been configured with the wrong control point name for the host computer. Verify the local configuration data in the LanRPC+ correctly describes the host computer.

- 403: Ready to connect to host.
 - ✓ A TCP/IP session with the host computer is being opened. This is a normal but transient status that exists briefly during startup of the main Controller connection to the host. No action is required. A 403 status should be considered to be an indication that session startup is proceeding normally. If a session reaches the 403 state and does not move on to some other state within a few seconds, contact I-O support.

- 404: Negotiation proceeding on Controller session.
 - ✓ A TCP/IP session with the host computer has been initiated, and parameters for the session are being exchanged between the LanRPC+ and the host. This status exists transiently during a normal successful session startup, but if the status persists more than a few seconds, it indicates a configuration problem.
 - The LanRPC+ has been configured with the wrong network id for the host computer. Verify the local configuration data in the LanRPC+ correctly describes the host computer.

- 405: Host has not started a session for this device.
 - ✓ The main TCP/IP connection between the LanRPC+ and the host computer has been started successfully, but the host computer has not yet started the TCP/IP session for this particular device.
 - The device description for this device is not varied on at the host. Verify the device is varied on at the host computer.
 - The TCP/IP Host Table entry for the LanRPC+ on the host computer contains either an incorrect IP address or an incorrect location name. Check the Host Table entry for the LanRPC+, and correct it if it contains incorrect information.
 - The host computer's APPN configuration list does not include an entry for the LanRPC+, or the entry contains incorrect information. Refer to the User Guide to determine whether the AnyNet setup you are using on your host computer requires the host's APPN configuration list include an entry for the LanRPC+. If such an entry is required, verify that a correct entry exists.

IPDS Error Conditions

| <i>Problem</i> | <i>Solution</i> |
|---|--|
| <ul style="list-style-type: none"> • IBM host shows IPDS printer still active yet the printer has been powered down. | <ul style="list-style-type: none"> ✓ When a printer has been powered off, the IBM host must be informed the printer is not available. Do this by manually stopping the print writer – take the *IMMED option to end the writer immediately eliminating the lengthy delay that will otherwise occur. |

LED Indicators

The following table describes the function of each LED on the LanRPC+. Use this information when troubleshooting the communication problems.

| <i>LED</i> | <i>Function</i> |
|--|--|
| <ul style="list-style-type: none"> • Link | <ul style="list-style-type: none"> ✓ This LED will be on indicating the LanRPC+ is up and running and has a good link with the Ethernet LAN. |
| <ul style="list-style-type: none"> • Activity | <ul style="list-style-type: none"> ✓ This LED will flash on and off as Ethernet packets are detected on the LAN. |
| <ul style="list-style-type: none"> • Power | <ul style="list-style-type: none"> ✓ When power is first applied, the blue LED around the power button lights up solid. The LanRPC+ performs a startup routine that may take up to 75 seconds to complete. During this time, the Line LED flashes in a sequence that indicates progress of the startup operation. <p>Initially, when power is plugged into the back of the LanRPC+, the Line LED will flash very slowly indicating the mother board is communicating with the Twin-ax card. This LED will go out when the LanRPC+ is powered off using the power button.</p> |
| <ul style="list-style-type: none"> • Ready | <ul style="list-style-type: none"> ✓ This LED indicates when the LanRPC+ has completed its startup operation and has connected with the host. <p>If the Ready LED does not come on solid within 90 seconds of power-up, a communications error has been encountered. Either a network cable is not connected, the host session has not been configured properly, or the LRPC+ does not detect a printer. In some cases, a flat screen monitor may be connected to the back of the LanRPC+ to help in diagnosing the problem.</p> <p>If the Ready LED goes out and has a slow heartbeat, the host is no longer communicating with the printer. Check the printer and/ or twin-ax cable to make sure the printer is communicating with the LanRPC+.</p> |

- Line 1
 - ✓ Off with a slow flashing heartbeat without the blue power light indicates power has been plugged into the mother board for the first time, but the LanRPC+ has not been powered on.
 - ✓ Off with a slow flashing heartbeat with the blue power light indicates that the LanRPC+ doesn't see a printer.
 - ✓ On with a fast flashing heartbeat with the blue power light on indicates the LanRPC+ is booting.
 - ✓ On solid with the blue power light on indicates the LanRPC+ has booted and a printer is ready.

Firmware Upgrade Process

Periodically new firmware is made available that contains enhancements and corrections for the LanRPC+. Before proceeding with the update, check your current Firmware and Driver versions. Contact I-O Tech Support for the current version available. This firmware may be downloaded using the following process:

1. Using your Web browser, navigate to ftp://ftp.iocorp.com/Host_Print/LAN_Print_Servers/LanRPC+/
2. Download to a temporary directory on your PC the **ctrlrpc** file which will contain the latest firmware version. The Build Date shown in the Configuration Utility should be more that a few days older than the ctrlrpc file you download. Otherwise you should be current on your firmware. Contact I-O Tech Support if you have questions on the current firmware version.

1-800-871-9998



NOTE: THE LANRPC+ FIRMWARE UPDATE.PDF FILE CONTAINS INSTRUCTIONS FOR UPDATING THE FIRMWARE ON THE LANRPC+. SINCE THE LANRPC+ IS USING A LINUX BASED PLATFORM, THE FIRMWARE UPDATE OPTION IN THE CONFIGURATION UTILITY DOES NOT WORK FOR THE LANRPC+.

THE LANRPC+ ALSO HAS A DRIVER VERSION FOR THE TWIN-AX CARD. THIS FIRMWARE CANNOT BE UPDATED IN THE FIELD. CONTACT I-O TECH SUPPORT TO FIND OUT IF THE FIRMWARE NEEDS TO BE UPDATED AND THE PROCEDURE FOR DOING SO.



TIP: IT IS SUGGESTED THAT WHEN YOU UPGRADE THE FIRMWARE, THAT YOU ALSO UPGRADE THE I-O CONFIGURATION UTILITY AT THE SAME TIME. GENERALLY YOU WILL WANT TO USE THE MOST RECENT VERSION OF THE I-O CONFIGURATION UTILITY.

3. Attach a monitor and usb keyboard to the back of the LanRPC+. Follow the instructions in the LanRPC+ Firmware Update.pdf file to update the firmware on the LanRPC+.
4. After the update, power off the LanRPC+ and power back on.



NOTE: REBOOTING THE LANRPC+ WILL TAKE APPROXIMATELY 30 SECONDS TO POWER DOWN AND ANOTHER 60 SECONDS FOR IT TO BECOME ACTIVE AFTER POWERING ON.

5. Open the Configuration Utility or Rescan for devices. Open the configuration of the LanRPC+ and make sure the Firmware has been updated.



TIP: IF A PRINTER DOES NOT APPEAR ON THE HOST, SEE TROUBLESHOOTING TO DETERMINE THE PROBLEM.

I-O Configuration Utility Upgrade Process

Periodically a new version of the I-O Configuration Utility is made available that contains enhancements and corrections. The LanRPC+ will require version 4.73 or higher. This software may be downloaded using the following process:

1. Using your Web browser, navigate to [ftp://ftp.iocorp.com/Utilities/Configuration Utility/Xip Plus/](ftp://ftp.iocorp.com/Utilities/Configuration%20Utility/Xip%20Plus/)
2. Download the latest version of the I-O Configuration Utility. Look for a file in the format of IOCU_xxx.exe. The xxx will be the version number.



TIP: THE I-O CONFIGURATION UTILITY IS BACKWARD COMPATIBLE AND WILL MANAGE PRINT SERVERS AND IP CONTROLLERS USING OLDER VERSIONS OF FIRMWARE.

3. After downloading the file, run the IOCU_xxx.exe file.
4. Follow the on-screen prompts.



NOTE: IF INSTALLING ON A WINDOWS 7 OR HIGHER PC OR SERVER, MANY TIMES YOU WILL NEED TO RIGHT CLICK ON THE PROGRAM AND RUN AS ADMINISTRATOR TO GET IT TO INSTALL.

Uninstalling the I-O Configuration Utility

The I-O Configuration Utility may be uninstalled using Microsoft's Add/Remove Programs process.

1. Click START | SETTINGS | CONTROL PANEL
2. Select the Add/Remove Programs icon.
3. Scroll to the I-O Configuration Utility entry and take the remove option.
4. Follow the on-screen prompts.

Restoring Factory Defaults

Factory defaults can be restored for all of the configuration options except a statically assigned IP Address.

Restoring Factory Defaults Using the I-O Configuration Utility

1. If you haven't already done so, start the I-O Configuration Utility.
2. Select the desired LanRPC+ from the displayed list.
3. Click on the Options menu and select Restore Factory Defaults.
4. Answer Yes on the Are you sure that you want to restore factory defaults message.
5. Dhcp will be enabled, however if a static address was previously assigned, that address will still be active on the LanRPC+.

Configuring a new IP address if the LanRPC+ doesn't show on the Configuration Utility

The LanRPC+ has a Linux mother board which is shipped from I-O Corp with Dhcp enabled. If for some reason you don't have a Dhcp server or the Print Server fails to accept a Dhcp address, you will need to manually assign an IP address on the LanRPC+.

This is done by attaching a monitor and keyboard to the back of the LanRPC+ and powering on the Print Server.

After the LanRPC+ boots up, press enter to get the io-login: prompt.

Login: 'root'

Password: 'io-0001'

After the Linux prompt, enter the command './setipadr'

This will prompt you for the IP address, Subnet Mask, and Default Gateway.

After entering these addresses, enter 'exit' and cycle power on the LanRPC+.

After booting up, you should be able to rescan for devices on the Configuration Utility and have the LanRPC+ show up. If not, make sure you can ping the LanRPC+. Click on View, Scan Options and select Scan for a specific device and enter the IP address you assigned the LanRPC+.

Host Communication Trace

It may be necessary to capture a complete communications trace of data being passed between the LanRPC+ and a host. This is done by starting, ending and printing a trace using IBM's commands at STRCMNTRC, ENDCMNTRC, and PRTCMNTRC.

See your IBM manuals for specific instruction on using these commands. You may also find on-line references to these commands at IBM's support site as follows:

Start a Trace

<http://publib.boulder.ibm.com/pubs/html/as400/v4r5/ic2924/index.htm?info/cl/strcmntr.htm>

End a Trace

<http://publib.boulder.ibm.com/pubs/html/as400/v4r5/ic2924/index.htm?info/cl/endcmntr.htm>

Print a Trace

<http://publib.boulder.ibm.com/pubs/html/as400/v4r5/ic2924/index.htm?info/cl/prtcmntr.htm>

Manufacturer's Warranty & Repair Policy

Manufacturer's Three Year Limited Warranty (United States)

The following warranty applies only to products purchased and operated within the United States.

I-O Corporation (I-O) warrants this product against defects in material and workmanship for a period of three years commencing from date of purchase by the original customer, when operated and maintained in accordance with I-O's published specifications. I-O's liability shall be limited, at its option and expense, to refund to buyer the actual amount paid by buyer or to repair or replace any defective or nonconforming product or part thereof, F.O.B. I-O's authorized repair depot. Buyer may obtain a replacement product by meeting the terms of the I-O Customer On-Site Exchange Repair Policy in effect at the time of the request.

THE EXPRESS WARRANTY SET FORTH ABOVE IS IN LIEU OF ALL OTHER EXPRESS OR IMPLIED WARRANTIES. OTHERWISE, THE PRODUCTS ARE SOLD AS IS WITHOUT FURTHER OBLIGATION OR LIABILITY ON THE PART OF I-O. I-O EXPRESSLY EXCLUDES ANY IMPLIED WARRANTIES OF MERCHANTABILITY AND FITNESS FOR A PARTICULAR PURPOSE.

EXCEPT AS EXPRESSLY SET FORTH HEREIN, IN NO EVENT SHALL I-O BE LIABLE FOR ANY CLAIMS OR DAMAGE ARISING DIRECTLY OR INDIRECTLY FROM THE FURNISHING OR FAILURE TO FURNISH PRODUCTS, SPARE OR REPLACEMENT PARTS, INFORMATION OR SERVICES HEREUNDER. UNDER NO CIRCUMSTANCES SHALL I-O BE LIABLE IN ANY WAY FOR INDIRECT, SPECIAL OR CONSEQUENTIAL DAMAGES, INCLUDING, BUT NOT LIMITED TO LOST BUSINESS OR PROFITS, WHETHER OR NOT FORESEEABLE AND WHETHER OR NOT BASED ON BREACH OF WARRANTY, CONTRACT, OR NEGLIGENCE.

I-O shall not be liable for non-performance or delays hereunder due to causes beyond its control. These shall include, but not be limited to, acts of God, wars, strikes, fires, flood, storm, earthquake, shortages of labor or materials, labor disputes, transportation embargoes, acts of any government or agency thereof.

MODIFICATIONS OR RECONFIGURATION OF THE HARDWARE BY ANYONE OTHER THAN I-O OR I-O'S AUTHORIZED REPAIR FACILITY WILL VOID THIS HARDWARE WARRANTY.

Customer On-Site Exchange Repair Policy

Terms, Conditions, and Limitations
Effective May 1, 1994^a

For products covered by the I-O Corporation (I-O) Manufacturer's Limited Warranty (United States), I-O's Customer On-Site Exchange (COE) Repair Policy provides customers with a replacement unit for a defective product, subject to the following terms and conditions:

Call Customer Support

If a product fails, call I-O Customer Support for assistance at (801) 972-1446.

Verify Product Failure

I-O will verify the product serial number, warranty coverage and product failure.

You are responsible for assisting in verifying the product failure.

When I-O Customer Support verifies a product failure they will issue a Return Merchandise Authorization (RMA) number for the failed product.

Replacement Units

Replacement units are shipped from I-O's stock of refurbished units, subject to availability.

Replacement units carry the same warranty as remaining on the original product.

I-O's COE Repair Policy applies only to warranted product failures. Buyer guarantees payment for non-warranted product repairs or replacement.

Buyer will pay reasonable labor and handling charges for each product returned for repair which is found to have no defect.

Return Your Failed Unit

When you return the failed product it must be shipped freight prepaid. Always note the RMA number on the outside of the package.

Install the Replacement Unit

You are responsible for installing the replacement unit.

After receiving the replacement unit please call I-O Customer Support if any assistance is required.

^a I-O reserves the right to change the terms and conditions of this policy without notice.

Manufacturer's Three Year Limited Warranty (International)

The following warranty applies only to products purchased or operated outside the United States.

I-O Corporation (I-O) warrants this product against defects in material and workmanship for a period of three years commencing from date of purchase by the original customer, when operated and maintained in accordance with I-O's published specifications. I-O's liability shall be limited, at its option and expense, to refund to buyer the actual amount paid by buyer or to repair or replace any defective or nonconforming product or part thereof, F.O.B. I-O's authorized repair depot. Buyer may obtain warranty service by meeting the terms of the I-O Return-to-Depot Repair Policy in effect at the time of the request.

THE EXPRESS WARRANTY SET FORTH ABOVE IS IN LIEU OF ALL OTHER EXPRESS OR IMPLIED WARRANTIES. OTHERWISE, THE PRODUCTS ARE SOLD AS IS WITHOUT FURTHER OBLIGATION OR LIABILITY ON THE PART OF I-O. I-O EXPRESSLY EXCLUDES ANY IMPLIED WARRANTIES OF MERCHANTABILITY AND FITNESS FOR A PARTICULAR PURPOSE.

EXCEPT AS EXPRESSLY SET FORTH HEREIN, IN NO EVENT SHALL I-O BE LIABLE FOR ANY CLAIMS OR DAMAGE ARISING DIRECTLY OR INDIRECTLY FROM THE FURNISHING OR FAILURE TO FURNISH PRODUCTS, SPARE OR REPLACEMENT PARTS, INFORMATION OR SERVICES HEREUNDER. UNDER NO CIRCUMSTANCES SHALL I-O BE LIABLE IN ANY WAY FOR INDIRECT, SPECIAL OR CONSEQUENTIAL DAMAGES, INCLUDING, BUT NOT LIMITED TO LOST BUSINESS OR PROFITS, WHETHER OR NOT FORESEEABLE AND WHETHER OR NOT BASED ON BREACH OF WARRANTY, CONTRACT, OR NEGLIGENCE.

I-O shall not be liable for non-performance or delays hereunder due to causes beyond its control. These shall include, but not be limited to, acts of God, wars, strikes, fires, flood, storm, earthquake, shortages of labor or materials, labor disputes, transportation embargoes, acts of any government or agency thereof.

MODIFICATIONS OR RECONFIGURATION OF THE HARDWARE BY ANYONE OTHER THAN I-O OR I-O'S AUTHORIZED REPAIR FACILITY WILL VOID THIS HARDWARE WARRANTY.

Return-to-Depot Repair Policy Terms, Conditions, and Limitations

Effective May 1, 1994^a

For products covered by the I-O Corporation (I-O) Manufacturer's Limited Warranty (International), I-O's Return-to-Depot (RTD) Repair Policy provides customers with warranty service for a defective product, subject to the following terms and conditions:

Call Customer Support

If a product fails, call I-O Customer Support for assistance at:
(801) 972-1446 for all locations outside the United States.

Verify Product Failure

I-O will verify the product serial number, warranty coverage and product failure.

You are responsible for assisting in verifying the product failure

When I-O Customer Support verifies a product failure they will issue a Return Merchandise Authorization (RMA) number to authorize return of the failed product.

Select Your Preferred Repair Location

I-O's Customer Support Representative will assist you in identifying the nearest I-O authorized repair depot.

I-O's Customer Support Representative will provide you with an RMA transmittal form referencing the assigned RMA number and the authorized repair depot address.

Return Your Failed Unit

Return the failed product to the I-O authorized repair depot previously identified, enclosing the RMA transmittal form. When you return the failed product it must be shipped freight prepaid.

I-O's RTD Repair Policy applies only to warranted product failures. Buyer guarantees payment for non-warranted product repairs.

Buyer will pay reasonable labor and handling charges for each product returned for repair which is found to have no defect.

Install Your Repaired Unit

I-O's authorized repair depot will service the faulty unit and return it to you, freight prepaid.

You are responsible for installing the returned unit.

After receiving the repaired unit please call I-O Customer Support if any assistance is required.

^aI-O reserves the right to change the terms and conditions of this policy without notice.